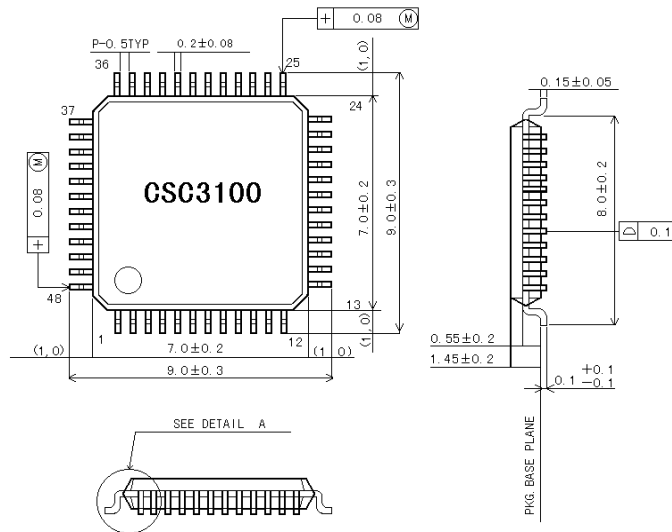

TFT LCD color monitor CSC3100**Description**

The CSC3100 is a compact multi-functional IC with a luminance, chroma, interface and sync separator circuit for the NTSC/PAL TFT LCD color monitors all integrated onto a single chip. This IC contains a luminance AGC circuit, gamma correction circuits to convert composite video signal or Y/C signal to RGB signal that meets the specific requirements of the LCD panels.

Applications

LCD color viewfinders, televisions and monitors

**Features**

- Low power dissipation (160mW TYP.)
- Applicable to both NTSC and PAL (Simple PAL only)
- Accepts composite video signal and Y/C signal input
- Built-in TRAP and HPF
- Built-in image control circuit
- Built-in AGC circuit (AGC OFF function)
- Built-in gamma correction circuits
- Built-in polarity inverter circuits
- Accepts external analog R.G.B. inputs
- Built-in RB output signal delay circuits (S/H form)
- Built-in Blanking circuits

*Not designed for rated as radiation hardened

*Packaging material: Plastic

*Chip material and wafer substrate type: P type silicon

*Number of pins and package type: 48-pin quad-flat Package (0.5mm pitch)

*Process (Structure): Bipolar

Terminal Name

Pin No.	Terminal Name	Pin No.	Terminal Name
1	TRAP	25	Vcc2
2	H FILTER OUT	26	BLK
3	VIDEO IN	27	SUB BRIGHT R
4	IDENT FILTER	28	SUB BRIGHT B
5	C IN	29	FRP
6	COLOR	30	GAMMA1
7	SW	31	GAMMA2
8	KILLER FILTER	32	BRIGHT
9	PEAK LIMITTER	33	S/H PULSE R
10	RGB AMPLITUDE	34	S/H PULSE G
11	ACC FILTER	35	S/H PULSE B
12	R-Y/B-Y PHASE	36	SYNC IN
13	TINT	37	SYNC OUT
14	VCO IN	38	SYNC SEP
15	APC FILTER	39	EXT B IN
16	VCO OUT	40	EXT G IN
17	GND	41	EXT R IN
18	V _{EE}	42	CONTRAST
19	R DC DET	43	Vcc1
20	R OUT	44	F ADJ
21	G DC DET	45	CLAMP
22	G OUT	46	AGC FILTER
23	B DC DET	47	AGC OUT
24	B OUT	48	PICTURE

Terminal Assignments (TOP VIEW)

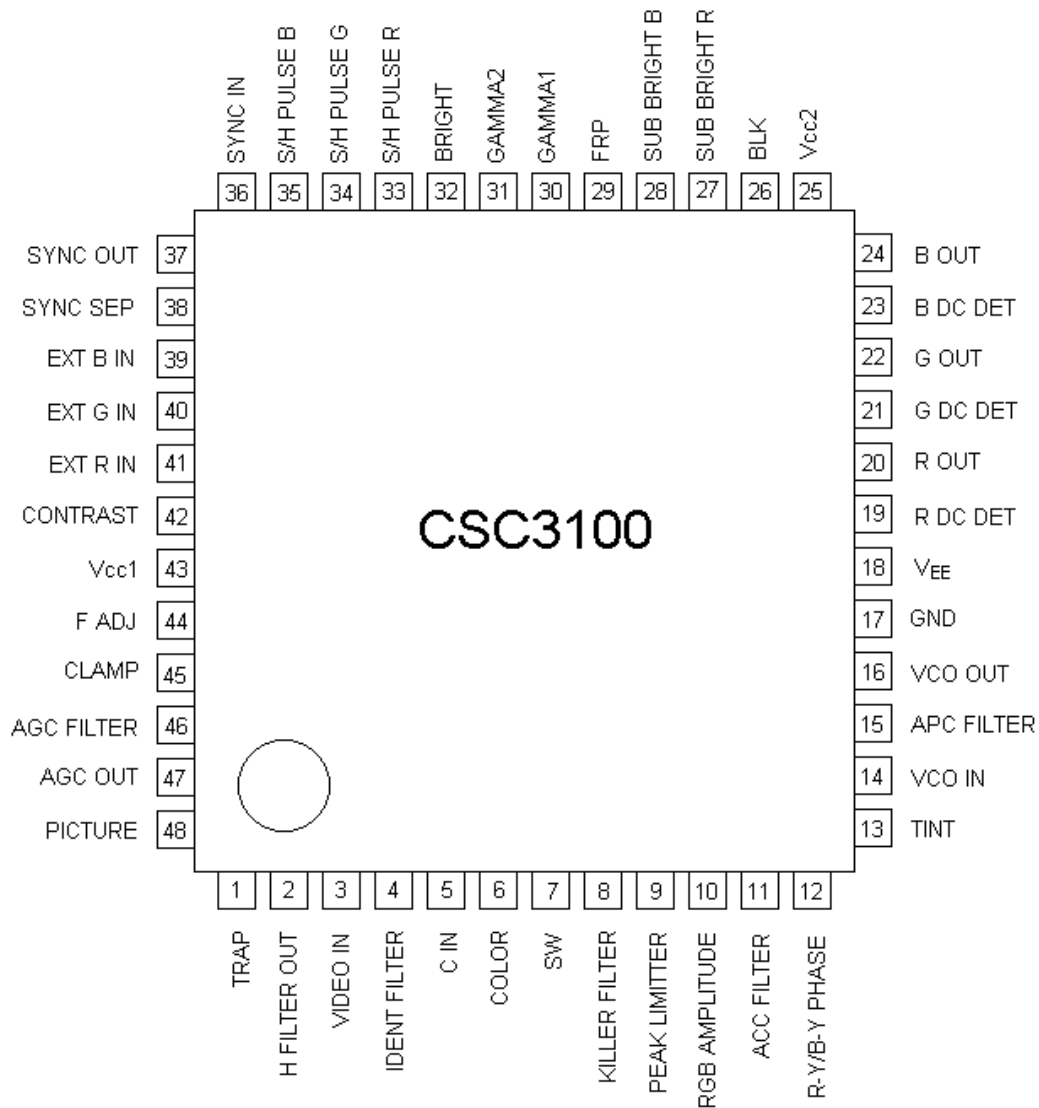

Block Diagram

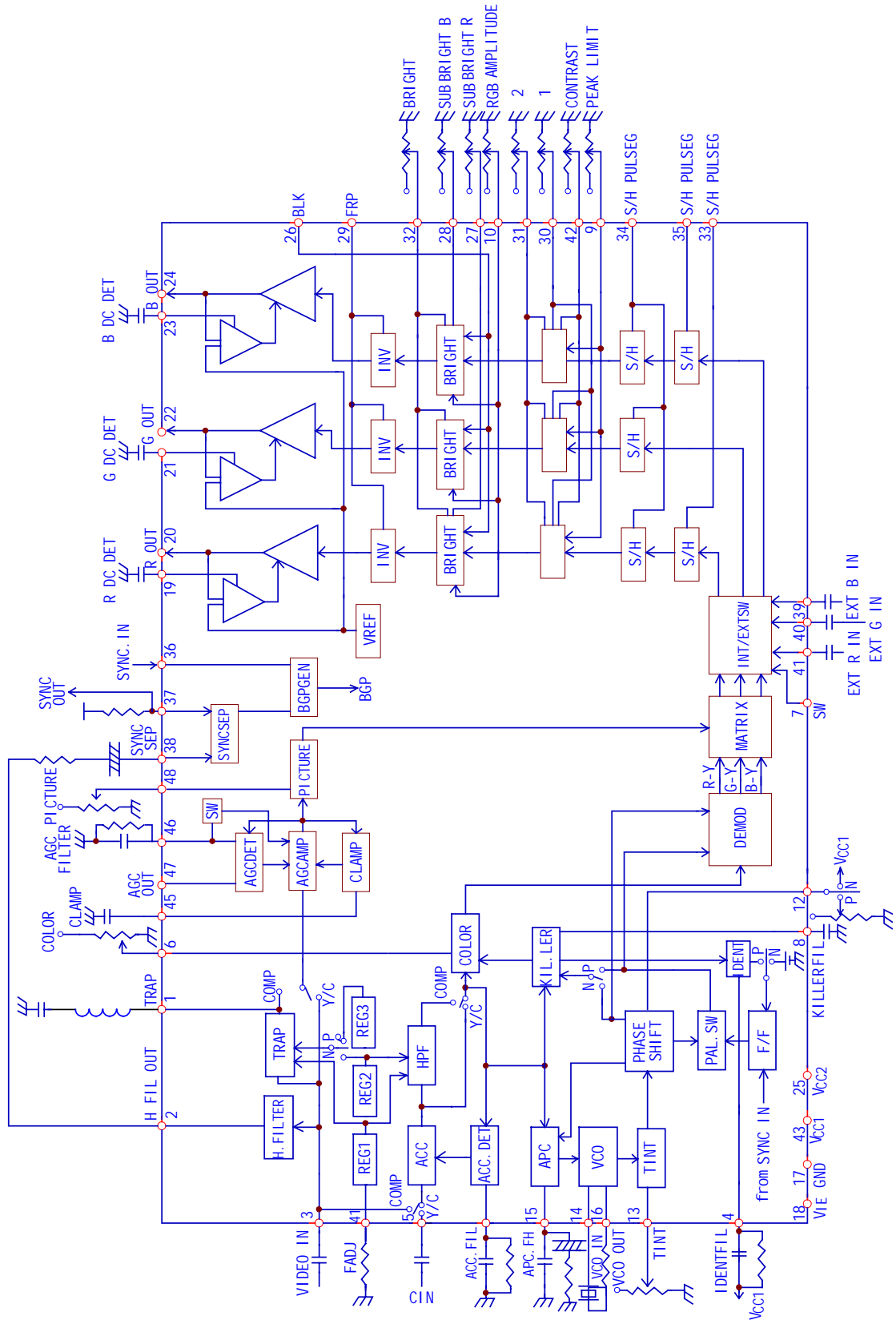

Description of Terminals ($V_{CC1}=4.5V$)

Term. No	Term. Name	Voltage	Equivalent Circuit	Description
1	TRAP	2.0V		Connected to TRAP.
2	H FILTER OUT			Outputs video signal for sync separator circuit.
3	VIDEO IN	2.25V		Input composite video signal. (Inputs luminance signal in the case of Y/C input).
4	IDENT FILTER			Connected to the IDENT detector filter.

Term. No	Term. Name	Voltage	Equivalent Circuit	Description
5	C IN	2.5V		Input the chrominance signal in the case of Y/C input. When this terminal is connected to ground, the composite video signal input is accepted.
6	COLOR			The DC voltage applied to this terminal adjusts the color gain.
7	SW			The input terminal for the source selection signal. Give the "Low" level in case of the VIDEO IN inputs, and give the "High" level in case of the EXT RGB IN inputs.
8	KILLER FILTER			Connected to the killer detector filter.

Term. No	Term. Name	Voltage	Equivalent Circuit	Description
9	PEAK LIMITER			The DC voltage applied to this terminal adjusts the while limit level.
10	RGB AMPLITUDE	0.7V		Adjusts the amplitude between the inverted level and the non-inverted level of the R.G.B. outputs. This terminal is preset inside the IC. Do not lower the DC voltage Under 0.7V.
11	ACC FILTER			Connected to the ACC detector filter.
12	R-Y/B-Y PHASE			Adjusts the angle of the R-Y/B-Y in case of the PAL mode. Connect to VCC1 for NTSC mode.

Term. No	Term. Name	Voltage	Equivalent Circuit	Description
13	TINT			The voltage applied to this terminal adjusts the tint. Corrects the color of output amplitude every 1H in case of the PAL mode.
14	VCO IN	3.9V		Input terminal for oscillator circuit.
15	APC FILTER			Connected to APC detector filter.
16	VCO OUT	2.7V		Output terminal for oscillator circuit.

Term. No	Term. Name	Voltage	Equivalent Circuit	Description
17	GND			Ground.
18	V _{EE}			Negative going power supply.
19 21 23	R DC DET G DC DET B DC DET			Connected to the capacitor That smoothes and holds the deviation from the R.G.B. outputs DC voltage. Because of the high impedance, use less leaky capacitor.
20 22 24	R OUT G OUT B OUT	$(V_{CC2} + V_{EE})/2$		Outputs the primary color signal.
25	V _{CC2}			Connected to power supply for the R.G.B. outputs.
26	BLK			The input terminal of the Blanking pulse. “High”: Blanking “Low”: No Blanking

Term. No	Term. Name	Voltage	Equivalent Circuit	Description
27 28	SUB BRIGHT R SUB BRIGHT B	1.5V		<p>The DC voltage applied to these terminals adjusts the brightness of the R and B signals finely. The gamma correction curve link the voltage of their terminals.</p> <p>These terminals are preset inside the IC.</p>
29	FRP			<p>Input the invert signal that goes “Low” level in the case of inverted and “High” level in the case of non-inverted.</p>
30	GAMMA1			<p>Adjusts the inflection point(1) on the DC voltage gain of the gamma correction.</p> <p>When this terminal is connected to Vcc1, the gamma correction is OFF.</p>
31	GAMMA2	1.5V		<p>Adjusts the inflection point(2) on the DC voltage gain of the gamma correction.</p> <p>This terminal is preset inside the IC.</p>

Term. No	Term. Name	Voltage	Equivalent Circuit	Description
32	BRIGHT			<p>The DC voltage applied to this terminal adjusts the brightness of RGB outputs.</p> <p>Gamma correction curve doesn't link this terminal voltage.</p>
33 34 35	S/H PULSE R S/H PULSE G S/H PULSE B			<p>Input the sampling pulse for RB output delay circuit.</p> <p>“High”: hold</p> <p>“Low”: sample</p> <p>“ALL Low”: No delay</p> <p>$V_{th}=1.5V$</p>
36	SYNC IN			<p>The rising edge of this input pulse must be before the fall edge of the SYNC OUT pulse.</p> <p>In the case of PAL mode, inner flip-flop switches at the rising of the input pulse.</p>
37	SYNC OUT			<p>Outputs the sync signal separated by the sync separator circuit.</p> <p>The output is provided by an open collector. This output signal goes “High” level when in sync and “Low” level when out of sync.</p>

Term. No	Term. Name	Voltage	Equivalent Circuit	Description
38	SYNC SEP	1.8V		Inputs the video signal to the sync separator circuit. Input the H FILTER output signal.
39 40 41	EXT B IN EXT G IN EXT R IN			The input terminal of the external analog RGB signal. The coupling capacitor works as a pedestal clamp capacitor.
42	CONTR-AST			The DC voltage applied to this terminal adjusts the contrast of R.G.B. output.
43	V _{CC1}			Connected to power supply.
44	F ADJ	1.2V		The value of the resistance connected between this terminal and GND adjusts the frequency characteristics of the filters. In the case of both NTSC and PAL mode, connect the resistance of 18k . Resistance accuracy $\pm 2\%$ Temp. stability $\pm 200\text{ppm}$.

Term. No	Term. Name	Voltage	Equivalent Circuit	Description
45	CLAMP			<p>Connected to the capacitor that clamps the pedestal of the luminance line.</p> <p>Because of the high impedance, Use less leaky capacitor.</p>
46	AGC FILTER			<p>Connected to the AGC detector filter for luminance line.</p> <p>When this terminal is connected to Vcc1, the AGC gain is fixed.</p>
47	AGC OUT			<p>Outputs the voltage detected at the AGC detector circuit for luminance line.</p> <p>The output voltage goes "High" at high-gain.</p>
48	PICTURE			<p>The DC voltage applied to this terminal adjusts the frequency characteristics of the luminance line.</p> <p>The outline is emphasized by reducing the terminal voltage.</p>

Absolute Maximum Ratings (Ta=25)

Parameter	Symbol	Condition	Rating	Units
Supply voltage	V _{CC1} -GND		7	V
	V _{CC2} -V _{EE}		17	V
	V _{EE} -GND		-10	V
Power dissipation	P _D	Ta 25	560	mW
Derating ratio		Ta > 25	4.5	mW/
Operating temperature range	Topr		-30~85	
Storage temperature range	Tstg		-55~50	
Each adjust pin voltage	V _{IN}		V _{CC1}	V
SYNC OUT output withstand voltage	V _{SD}		V _{EE} +17	V
Video input pin signal voltage	V _{VDIN}		3	Vp-p
External input pin signal voltage	EXT _{IN}		V _{CC1}	V
FRP input pin signal voltage	FRP _{IN}		V _{CC1}	V
SYNC IN input pin signal voltage	SYNC _{IN}		V _{CC1}	V

Operating supply voltage ranges

Parameter	Symbol	Rating	Units
Operating supply voltage range	V _{CC1} -GND	4.25~5.25	V
	V _{CC2} -GND	4.25~16	V
	V _{EE} -GND	-8.75~0	V
	V _{CC2} -V _{EE}	11.25~16	V

Recommended operating conditions

Parameter	Symbol	Condition	Rating	Units
COMPOSITE VIDEO IN input signal voltage	V _{VDIN}	Pedestal-white	0.7	Vp-p
LUMINANCE IN input signal voltage	Y _{IN}	Pedestal-white	0.7	Vp-p
CHROMINANCE IN input signal voltage	C _{IN}	Amplitude of burst signal	0.3	Vp-p
Adjust terminal input voltage	V _{IS}		0~3.0	V
External input pin signal voltage	EXT _{IN}	Pedestal-white	0.7	Vp-p
Sampling pulse voltage	V _{SN}		3.0~V _{CC1}	V

Electrical characteristics

DC characteristics

Unless otherwise specified, $V_{CC1} = 4.5V, V_{CC2} = 12V, V_{EE} = GND, T_a = 25^\circ C, SW5 = a, SW8 = a, SW10 = OFF, SW20 = OFF, SW22 = OFF, SW24 = OFF, SW26 = b, SW27 = OFF, SW28 = OFF, SW31 = OFF, SW33 = b, SW34 = b, SW35 = b, SW38 = a, SW46 = OFF; V_6 = 2.6V, V_7 = 0V, V_9 = 3.0V, V_{12} = 4.5V, V_{13} = 1.5V, V_{26} = 0V, V_{30} = 3.0V, V_{32} = 2.1V, V_{33} = 0V, V_{34} = 0V, V_{35} = 0V, V_{42} = 1.5V, V_{48} = 1.5V$ SG11 applied to (C) and SG7b (4.5Vp-p) applied to (D).

Parameter	Symbol	Condition	MIN.	TYP.	MAX.	Units
Current dissipation (pin 43)	I_{CC1}			25	35	mA
Current dissipation (pin 25)	I_{CC2}			3.0	4.3	mA
Current dissipation (pin 43) operation in S/H circuit	I_{CC1}			27	37	mA
TRAP output impedance	Z1			1.0		K
VIDEO IN input impedance	Z3			12		K
C IN input impedance	Z5			3.6		K
RGB AMPLITUDE input impedance	Z10			53		K
SUB BRIGHT R input impedance	Z27			153		K
SUB BRIGHT B input impedance	Z28			153		K
GAMMA 2 input impedance	Z31			53		K
C IN input current	I5	V5=GND		4.0	6.0	μA
COLOR input current	I6	V6=GND		-0.3	-1.0	μA
SW input current	I7	V7=GND		-0.3	-1.0	μA
PEAK LIMITTER input current	I9	V9=GND		-0.3	-1.0	μA
R-Y/B-Y PHASE input current H	I12H	V12=GND		0.2	0.1	μA
R-Y/B-Y PHASE input current L	I12L	V12=GND		-0.3	-1.0	μA
TINT input current	I13	V13=GND		-0.3	-1.0	μA
BLK input current	I26	V26=GND		-0.2	-1.0	μA
FRP input current	I29	V29=GND		-0.2	-1.0	μA
GAMMA 1 input current H	I30H	V30=4.5V		0.2	1.0	μA
GAMMA 1 input current L	I30L	V30=GND		-0.3	-1.0	μA
BRIGHT input current	I32	V32=2.5V		0.2	1.0	μA
S/H PULSE R input current	I33	V33=GND		-0.5	-2.0	μA
S/H PULSE G input current	I34	V34=GND		-0.5	-2.0	μA
S/H PULSE B input current	I35	V35=GND		-0.5	-2.0	μA
SYNC IN input current	I36	V36=GND		-0.2	-1.0	μA
CONTRAST input current	I42	V42=GND		-0.2	-1.0	μA
PICTURE input current	T48	V48=GND		-0.5	-2.0	μA
TRAP terminal voltage	V1		1.7	2.0	2.3	V
VIDEO IN terminal voltage	V3		1.95	2.25	2.55	V

Parameter	Symbol	Condition	MIN.	TYP.	MAX.	Units
C IN terminal voltage	V5		2.2	2.5	2.8	V
RGB AMPLITUDE terminal voltage	V10	V10=OPEN	0.4	0.7	1.0	V
VCO IN terminal voltage	V14		3.6	3.9	4.2	V
VCO OUT terminal voltage	V16		2.4	2.7	3.0	V
SUB BRIGHT R terminal voltage	V27	V27=OPEN	1.2	1.5	1.8	V
SUB BRIGHT B terminal voltage	V28	V28=OPEN	1.2	1.5	1.8	V
GAMMA 2 terminal voltage	V31	V31=OPEN	1.2	1.5	1.8	V
SYNC SEP terminal voltage	V38		1.4	1.8	2.2	V
F ADJ terminal voltage	V44		0.9	1.2	1.5	V

AC characteristics

Unless otherwise specified: $V_{CC1}=4.5V, V_{CC2}=12V, V_{EE}=GND, T_a=25^\circ C, SW5$ a, $SW7$ b, $SW8$ a, $SW10$ OFF, $SW20$ OFF, $SW22$ OFF, $SW24$ OFF, $SW26$ b, $SW27$ OFF, $SW28$ OFF, $SW31$ OFF, $SW33$ b, $SW34$ b, $SW35$ b, $SW38$ a, $SW46$ OFF; $V5=0V, V6=1.5V, V7=0V, V9=3.0V, V12=4.5V, V13=1.5V, V26=0V, V30=4.5V, V32=2.1V, V33=0V, V34=0V, V35=0V, V42=3.0V, V46=4.5V, V48=2.5V$ SG11 applied to (C) and SG7b (4.5V_{p-p}) applied to (D).

Parameter	Symbol	Conditions	MIN	TYP	MAX	Units
Video Part:						
Luminance maximum gain (1) (AGC ON)	Gmax1	With V42=0V and SG8 (-17dB) applied to (A). Measures the ratio of the output amplitude (black-white) to the input amplitude on TP22.	32	35	38	dB
Luminance maximum gain (2) (AGC OFF)	Gmax2	With V42=0V, SW46 ON, V46=4.5V and SG8 (-17dB) applied to (A). Measure the ratio of the output amplitude (black-white) to the input amplitude on TP22.	27	30	33	dB
AGC ON-OFF switch voltage	Vth _{AGC}	Measure the DC voltage on TP46 that causes TP22 to change from Luminance maximum gain to Gmax2.	3.7	4.0	4.2	V
AGC amplitude characteristics	Va1	With SW46 OFF, SG1 (0dB) applied to (A), and APL =50%, adjust V42 so that the amplitude (black-3rd level) of the output on TP22 is 4V. Observe the waveform on TP22 as APL is changed to 10% and 90%. The amplitude (Black-3rd level) at these APL shall be Va1 and Va2 respectively.	4.5	5.5	6.5	V _{p-p}
	Va2		2.1	2.6	3.1	

Parameter	Symbol	Conditions	MIN	TYP	MAX	Units
AGC detection output voltage	Vad1	With SW46 OFF, SG1 (0dB) applied to (A),when APL is changed to 10%,50% and 90%, the voltages on TP47 shall be Vad1,Vad2 and Vad3 respectively.	2.2	2.7	3.2	V
	Vad2		1.0	1.5	2.0	
	Vad3		0.2	0.4	0.7	
Image quality adjust Variable range (composite signal input, NTSC)	Gp1	With SW5 b and SG2 (100kHz) applied to (A),adjust V42 so that the amplitude of the 100kHz component on TP22 is 1V _{P-P} . With SG2 (f=1.6MHz) applied, observe the difference of the amplitude on TP22 as V48 is changed to 0V and 3V.	3.0	7.0		dB
	Gp2	The amplitude difference at these two V48 voltages shall be Gp1 and Gp2, respectively		-2.0	1.0	dB
Image quality adjust Variable range (composite signal input, PAL)	Gp3	With SW5 b, V12=1.5V and SG2 (100kHz) applied to (A),adjust V42 so that the amplitude of the 100kHz component on TP22 is 1V _{P-P} . With SG2 (f=1.6MHz) applied, observe the difference of the amplitude on TP22 as V48 is changed to 0V and 3V.	3.0	7.0		dB
	Gp4	The amplitude difference at these two V48 Voltages shall be Gp3 and Gp4, respectively.		-2.0	1.0	
Image quality adjust variable range (Y/C input)	Gp5	With SG2 (100kHz) applied to (A), adjust V42 so that the amplitude of the 100kHz component on TP22 is 1V _{P-P} . With SG2 (f=2.0MHz) applied, observe the difference of the amplitude on TP22 as V48 is changed to 0V and 3V.	7.0	11.0		dB
	Gp6	The amplitude difference at these two V48 voltages shall be Gp5 and Gp6, respectively.		0	3.0	

Parameter	Symbol	Conditions	MIN	TYP	MAX	Units
Trap attenuation (NTSC)	Gtf (NT)	With SG3 (f=100KHz, 0dB) applied to (A), observe the waveform on TP1, the amplitude of the 100kHz component of the signal shall be v0. Then, apply SG3 (f=3.58MHz, 0dB), the amplitude of the 3.58MHz component on TP1 shall be v1. Gtf = 20log (v1/v0)	-30	-47		dB
Trap attenuation (PAL)	Gtf (PAL)	With V12=1.5V, and SG3 (f=100KHz, 0dB) applied to (A), observe the waveform on TP1, the amplitude of the 100kHz component of the signal shall be v0. Then, apply SG3 (f=4.43MHz, 0dB), the amplitude of the 4.43MHz component on shall be v1. Gtf = 20log (v1/v0)	-30	-47		dB
DC reproduction ratio	K	With SG1 (APL10%, 0dB), applied to (A), measure the amplitude (black-black) on TP22. Let the measured amplitude be V1. Then with SG1 (APL90%, 0dB) applied to (A), measure the amplitude (black-black) on TP22. Let the measured amplitude be V2. K = (V1 - V1 - V2) / v1 × 100	95			%
Chroma part:						
ACC characteristics (composite input, NTSC)	GA1	With SW5 b and SG5 (0dB, +6dB, -25 dB, burst/chroma phase=180°) applied to (A), measure the amplitude of waveform on TP24 at 0dB, +6dB and -25dB. Let the measured amplitude for each input be v0, v1 and v2. GA1 = 20 log(v1/v0) GA2 = 20 log(v2/v0)		0	2.0	dB
	GA2		-12	-4.0		

Parameter	Symbol	Conditions	MIN	TYP	MAX	Units
ACC characteristics (Y/C signal input, NTSC)	GA3	With SG5 (0dB,+6dB,-25dB,burst/chroma phase=180 °) applied to (B),measure the amplitude of waveform on TP24 at 0dB , +6dB and -25dB.Let the measured amplitude for each input be v0, v1 and v2.		0	2.0	dB
	GA4	GA3=20 log(v1/v0) GA4=20 log(v2/v0)	-5.0	0		
ACC characteristics (composite signal input, PAL)	GA5	With SW5 b,V12=1.5V and SG5 (0dB,+6dB,-25dB,burst/chroma phase= ± 135 °) applied to (A),measure the amplitude of waveform on TP24 at 0 dB , +6dB and -25dB.Let the measured amplitude for each input be v0,v1 and v2.		0	2.0	dB
	GA6	GA5=20 log(v1/v0) GA6=20 log(v2/v0)	-10	-3.0		
ACC characteristics (Y/C signal input, PAL)	GA7	With V12=1.5V and SG5 (0dB,+6dB,-25dB,burst/chroma phase= ± 135 °) applied to (B),measure the amplitude of waveform on TP24 at 0 dB , +6dB and -25dB.Let the measured amplitude for each input be v0,v1 and v2.		0	2.0	dB
	GA8	GA7=20 log(v1/v0) GA8=20 log(v2/v0)	-5.0	0		
Color control gain variable range	GC1	With SG5 (0dB, burst/chroma phase=180 °) applied to (B),allowV6 to change to 0V,1.5V then 3V to measure the amplitude on TP24. Let these amplitudes be V1,V0 and V2, respectively.		-30	-20	dB
	GC2	GC1=20 log(V1/V0) GC2=20 log(V2/V0)	4.0	6.0		
APC capture range (NTSC)	fA1	With SG5 (0dB) applied to (B),allow the frequency of the burst signal to change to measure the input frequency at which the voltage on TP8 drops below 2V.Work out the difference by subtracting the measured frequency from 3.579545MHz.	± 500	+1500 -800		Hz

Parameter	Symbol	Conditions	MIN	TYP	MAX	Units
APC capture range (PAL)	fA2	With V12=1.5V and SG5 (0dB) applied to (B), allow the frequency of the burst signal to change to measure the input frequency at which the voltage on TP8 drops below 2V. Work out the difference by subtracting the measured frequency from 4.433619MHz.	± 500	+1300 -1700		Hz
Killer operating input level (NTSC)	Vbk1	With SG5 (variable amplitude, burst/chroma phase=180 °) applied to (B), observe the waveform on TP24 as decreasing the input amplitude until the killer turns on. Measure the input attenuation.		-46	-40	dB
Killer operating input level (PAL)	Vbk2	With V12=1.5V and SG5 (variable amplitude, burst/chroma phase= ± 135 °) applied to (B), observe the waveform on TP24 as decreasing the input amplitude until the killer turns on. Measure the input attenuation.		-43	-37	dB
Killer color ghost (NTSC)	Vbs1	With SW8 b and SG5 (burst/chroma phase =180 °) applied to (B), measure the amplitude of the color different output on TP24.		50	100	mV p-p
Killer color ghost (PAL)	Vbs2	With SW8 b, V12=1.5V, and SG5 (burst/chroma phase = ± 135 °) applied to (B), measure the amplitude of the color different output on TP24.		90	180	mV p-p
Demodulation output ratio (NTSC)	(R-Y)/ (B-Y)	With SG5 (0dB) applied to (B), allow the chroma phase to change. Let the amplitude causing the maximum amplitude on TP20 be VR. Let the amplitude causing the maximum amplitude on TP22 be VG.	0.46	0.56	0.66	
	(G-Y)/ (B-Y)	Let the amplitude causing the maximum amplitude on TP24 be VB. (R-Y)/(B-Y)=VR/VB (G-Y)/(B-Y)=VG/VB	0.26	0.34	0.42	

Parameter	Symbol	Conditions	MIN	TYP	MAX	Units
Demodulation output ratio (PAL)	(R-Y)/ (B-Y)	With V12=1.5V and SG5 (0dB) applied to (B), allow the chroma phase to change. Let the amplitude causing the maximum amplitude on TP20 be VR. Let the amplitude causing the maximum amplitude on TP22 be VG.	0.44	0.54	0.64	
	(G-Y)/ (B-Y)	Let the amplitude causing the maximum amplitude on TP24 be VB. (R-Y)/(B-Y)=VR/VB (G-Y)/(B-Y)=VG/VB	0.26	0.34	0.42	
Demodulation relative phase (NTSC)	RB	With SG5 (0dB) applied to (B), allow the chroma phase to change. Let the angle causing the maximum amplitude on TP20 be R.	80	90	100	deg.
	GB	Let the angle causing the maximum amplitude on TP22 be G. Let the angle causing the maximum amplitude on TP24 be B. RB= R- B, GB= G- B	225	235	245	
Demodulation relative phase(PAL)	RB	With V12=1.5V and SG5 (0dB) applied to (B), allow the chroma phase to change. Let the angle the causing maximum amplitude on TP20 be R.	80	90	100	deg.
	GB	Let the angle the causing maximum amplitude on TP22 be G. Let the angle the causing maximum amplitude on TP24 be B. RB= R- B, GB= G- B	220	230	245	
Demodulation output residual carrier (NTSC)	VCAR (N)	With (C) = OPEN and SG5 (burst/chroma phase =180 °) applied to (B),adjust the chroma phase so that the amplitude on TP24 is at its maximum. Observe TP24 with a spectrum analyzer to measure the ratio of V1 to V0, where V1 is the 7.15909MHz component, V0 being the 15.734kHz component. vCAR1=20 log(V1/V0)		-60	-40	dB

Parameter	Symbol	Conditions	MIN	TYP	MAX	Units
Demodulation output residual carrier(PAL)	VCAR (P)	With V12=1.5V, (C) = OPEN and SG5 (0dB, burst/chroma phase $\pm 135^\circ$) applied to (B), adjust the chroma phase so that the amplitude on TP24 is at its maximum. Observe TP24 with a spectrum analyzer to measure the ratio of V1 to V0, where V1 is the 8.867238MHz component, V0 being the 15.625kHz component. $vCAR2=20 \log (V1/V0)$		-65	-45	dB
TINT variable range	+	With SG5 (0dB) applied to (B), allow the chroma phase to change. Let the angle causing the maximum amplitude on TP24 be 1 in the case of V13=0V. Let the angle causing the maximum amplitude on TP24 be 2 in the case of V13=1.5V.	30	40		deg.
	-	Let the angle causing the maximum amplitude on TP24 be 3 in the case of V13=3.0V. $+ = 1 - 2 \quad - = 3 - 2$	-30	-40		
Composite Y/C input switching voltage	VthCY	With SW5 b and SG5(0dB, burst/chroma phase =180°) applied to (A), increase V5 from 0V until the signal from TP24 disappears. Measure the voltage on V5 that causes the signal to disappear.	1.3	1.5	1.7	V
Y/C composite input switching voltage	VthYC	With SW5 b and SG5(0dB, burst/chroma Phase = $\pm 135^\circ$) applied to (A), decrease V5 from 0V until the signal from TP24 appears. Measure the voltage on V5 that causes the signal to appear.	0.7	0.9	1.1	V
NTSC PAL	VthNP	With SG5 (0dB, burst/chroma phase =180°) applied to (B), decrease V12 until the signal from TP24 disappears. Measure the voltage on V12 that causes the signal to disappear.	3.4	3.7	4.0	V

Interface part

Paramrter	Symbol	Conditions	MIN	TYP	MAX	Units
Contrast adjust gain variable range	Gct	With SG8 (-14dB) applied to (A),observe the waveform on TP22 as V42 is changed to 0V then 3V. The amplitude between the black level and the white level at these voltages shall be v1 and v2, respectively. $Gct=20 \log(v1/v2)$		-15	-11	dB
Brightness adjust variable range	Vb1	With no input to (A) and (B). V32=1.8V. Measure the amplitudes (black-black) on TP20,TP22 and TP24.	9.0			Vp-p
Brightness adjust variable range	Vb2	With no input to (A) and (B). V32=2.8V. Measure the amplitudes (black-black) on TP20,TP22 and TP24.			1.0	Vp-p
Sub-brightness adjust variable range	Vsb	With no input to (A) and (B). V32=2.3V. V27=0V and 3V, V28=0V and 3V measure the amplitudes difference (black-black) on TP20 and TP24 between SW27 OFF, SW28 OFF and SW27 ON , SW28 ON.	± 1.0	± 2.3		V
RGB output DC voltage	VRGB	With no input to (A) and (B), adjust V32 to set the amplitude on TP22 to 9Vp-p (black-black) and measure the DC voltage on TP20, TP22 and TP24.	5.8	6.0	6.2	V
RGB output black level voltage difference	VBL	With no input to (A) and (B), measure the black level voltage difference between maximum and minimum black level voltage on TP20, TP22 and TP24 in invert mode and non invert mode.			300	mV
Gain difference between invert and non-invert	Ginv	With V42=1.5V and SG8 (-11dB) applied to (A) , measure the amplitude (black-white) difference invert and non-invert on TP20,TP22 and TP24.		± 0.3	± 0.6	dB
Gain difference among RGB	GRGB	With V42=1.5V and SG8 (-11dB) applied to (A) , measure the amplitude differences (white-black) between maximum and minimum level on TP20,TP22 and TP24 in non invert mode.		0.3	0.6	dB

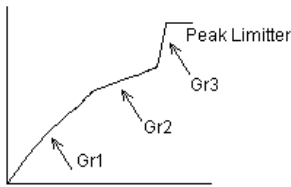
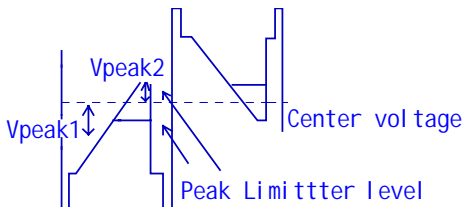
Parameter	Symbol	Conditions	MIN.	TYP.	MAX	Units
FRP pin threshold voltage	VthFRP	With V42=1.5V and SG8(-11dB) applied to (A) , increase the voltage on (C) from 0V until the signals from TP20, TP22 and TP24 are inverted. Measure the voltage on (C) that inverts these signals.	1.3	1.6	1.9	V
Gamma correction characteristics	G 1	With V30=1.5V,SW31 ON,V31=1.5V, V42=0V (CONTRAST set Maximum) , and SG9 applied to (A), measure the gain each specific point on the output waveform of TP20,TP22 and TP24. 	32	35	38	dB
	G 2		17	21	25	
	G 3		32	35	38	
Peak limiter characteristics	V _{PEAK1}	With V42=0V and SG9 applied to (A).Then V9=0.5V and V9=3V,measure the amplitude difference (center level-peak limiter level) on TP20,TP22 和 TP24. 	2.5	3.0	3.5	V
	V _{PEAK2}		-4.8	-4.2	-3.6	
Input-Output propagation delay time (composite video signal input)	tpLH1	With SG4 applied to (A),SW5 b ,SW20 ON,SW22 ON,SW24 ON. Adjust V42 so that the amplitude (black-white) of TP20,TP22 and TP24 are 5Vp-p and measure the propagation delay time of the rising edge tpLH1, and that of the falling edge tpHL1.	450	660	870	ns
	tpHL1		450	660	870	

Parameter	Symbol	Conditions	MIN.	TYP.	MAX	Units
Input-Output propagation delay time (Y/C input)	tpLH2	With SG4 applied to (A),SW20 ON, SW22 ON,SW24 ON. Adjust V42 so that the amplitude (black-white) of TP20,TP22 and TP24 are 5Vp-p and measure the propagation delay time of the rising edge tpLH2, and that of the falling edge tpHL2.	300	500	700	ns
	tpHL2		300	500	700	
EXT-Output Propagation delay time	tpLH3	With SW20 ON,SW22 ON,SW24 ON , V7=3.0V and SG4 applied to (F), (G) ,(H). Adjust V42 so that the amplitude (black-white) of TP20,TP22 and TP24 are 5Vp-p and measure the propagation delay time of the rising edge tpLH3, and that of the falling edge tpHL3.	30	80	130	ns
	tpHL3		60	120	180	
RGB output Rise time, Fall time (External input)	tTLH	With SW20 ON,SW22 ON,SW24 ON,V7=3.0V and SG10 applied to (F), (G), (H). Adjust V42 so that the amplitude (black-white) of TP20, TP22 and TP24are 5Vp-p and measure the propagation delay time of the rising edge tTLH, and that of the falling edge tTHL.	40	90	160	ns
	tTHL		60	110	180	
Frequency characteristics	f1	With SW46 ON, SW20 ON,SW22 ON,SW24 ON, SG2(100KHz) applied to (A), measure the frequency f1 when the amplitude of the output TP20, TP22 and TP24 decreases 3 dB lower than that of 100kHz at V48=0V, f2 at V48=3V.	4.5	7.0		MHz
	f2		3.5	5.0		
	f3	With V7=V3, SG2 applied to (F), (G) and (H), measure the frequency f3 similarly.	2.5	3.7		
RGB output amplitude adjust variable range	V _{RGB}	With no input to (A) and (B). Measure the amplitude differences (black-black) on TP20, TP22 and TP24 between SW10 OFF and SW10 ON, V10=3V.	4.0	5.1		V
BLK threshold voltage	V _{thBLK}	With SG8(-11dB) applied to (A), increase V26 from 0V until the signal of TP24 disappears. Measure the voltage on V26 that causes the signal to start disappearing.	1.2	1.5	1.9	V

Parameter	Symbol	Conditions	MIN.	TYP.	MAX	Units
S/H linear error	E _{LSHR}	With V7=3.0V, (K)= “Low”,(L)=“Hi”, SG12a applied to (J), SG12b applied to (H). Define, adjust amplitude on SG12b to 0.2Vp-p and 0.7Vp-p, measure the amplitude on TP20 as v1 and v2.	90	100		%
	E _{LSHG}	Then (J)= “Hi”,(L)= “Low”, SG12a applied to (K), SG12b applied to (G). Define, adjust amplitude on SG12b to 0.2Vp-p and 0.7Vp-p, measure the amplitude on TP22 as v3 and v4.	90	100		
	E _{LSHB}	Then (J)= “Hi”,(K)= “Low”, SG12a applied to (L), SG12b applied to (F). Define, adjust amplitude on SG12b to 0.2Vp-p and 0.7Vp-p, measure the amplitude on TP24 as v5 and v6. E _{LSHR} =(0.2v2/0.7v1) × 100 E _{LSHG} =(0.2v4/0.7v3) × 100 E _{LSHB} =(0.2v6/0.7v5) × 100	90	100		
SW propagation delay time	tpLH4	With no input to (A),SG10 applied to (M), SG4 applied to (F), (G) and (H), SW7 a, SW20 ON,SW22 ON,SW24 ON.	60	120	180	ns
	tpHL4	Adjust V42 so that the amplitude (black-white) of TP20, TP22 and TP24 are 5Vp-p and measure the waveform of TP20, TP22 and TP24.	70	130	190	
BLK propagation delay time	tpLH5	With V32=2.5V, SG10 applied to (I), SW26 a, SW20 ON , SW22 ON,SW24 ON.	70	150	210	ns
	tpHL5	Adjust V42 so that the amplitude (black-white) of TP20, TP22 and TP24 are 5Vp-p and measure the waveform of TP20, TP22 and TP24.	140	210	290	
SW switching voltage	V _{thsw}	With SW7 a, SG8 applied to (F), Increase V7 from 0V until the signal on TP24 appears. Measure the voltage on V7 that cause the signal to start appearing.	0.6	0.8	1.0	V

Parameter	Symbol	Conditions	MIN.	TYP.	MAX	Units
Input-Output maximum gain (External input)	G _{ext}	With SW7 a, V42=0V, SG8(-14dB) applied to (F), (G) and (H). Measure the ratio of the output amplitude (white-black) on TP20, TP22 and TP24 to the input amplitude.	27	30	33	dB
Inside-Outside Voltage gain difference	G _{IN/EXT}	With SW5 b, SW7 a, SW46 ON, SG8 applied to (F), (G) and (H). Measure the amplitude (white-black) difference between output amplitude and with SG8 applied to (A), output amplitude on TP20, TP22 and TP24.	-2.0		2.0	dB

Sync part

Parameter	Symbol	Conditions	MIN.	TYP.	MAX	Units
Sync separator input sensitivity current	I _{is}	Allow the current to flow out of (E), and measure the input current that causes TP37 to go from “Low”(GND) to “High”(VCC).		22	30	μ A
Sync separator output ON-start voltage	V _{on}	Measure the output voltage on TP37.		0.2	0.5	V
External sync input threshold voltage	V _{eth}	Increase the amplitude of SG7b from 0V and measure the amplitude of SG7b that causes the clamp circuit to start operating.	1.2	1.5	1.8	V
H filter output gain	G _{hf}	With SG7a applied to (A), measure the amplitude on TP2.	3.5	4.5	6.5	dB
H filter output propagation delay time	tp _{LH} (HF)	With SG7a applied to (A), measure the Propagation delay time to TP2. rise time tp _{LH} (HF) fall time tp _{HL} (HF)	500	900	1300	ns
	tp _{HL} (HF)		300	500	800	
Sync separator output propagation delay time	Tp _{LH} (sync)	With SW38 b, SG7a(0.15Vp-p) applied to (A), measure the propagation delay time to TP37. rise time tp _{LH} (sy) fall time tp _{HL} (sy)	0.6	1.0	1.6	μ s
	Tp _{HL} (sync)		0.3	0.7	1.1	

Test circuit

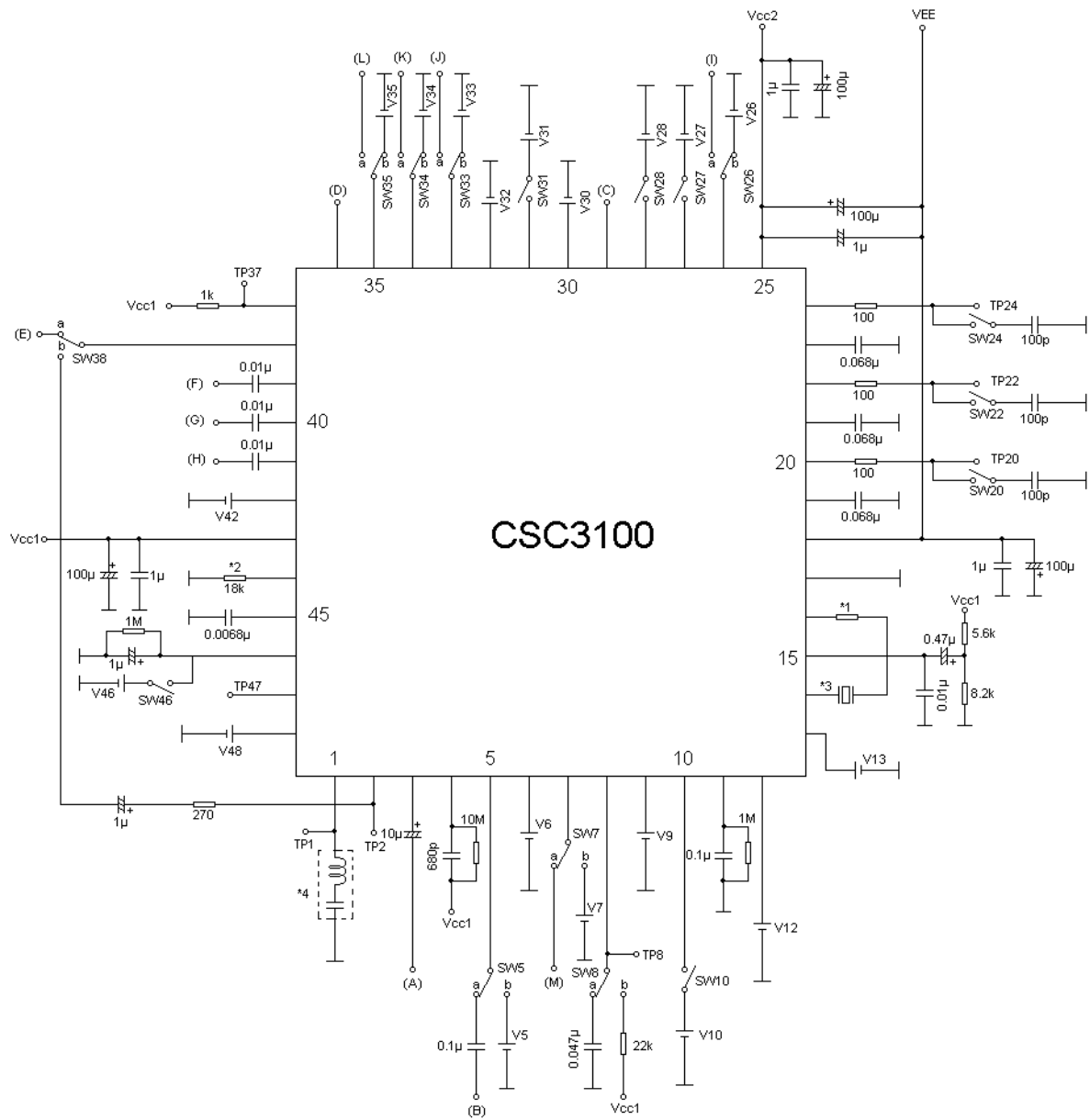

*1. 1K (NTSC), SHORT (PAL)

*2. Resistance Variability $\pm 2\%$, Temperature Characteristics $\pm 200\text{ppm}/$

*3. DAISHINKU CORPORATION AT-49

Frequency: 3.579545MHz (NTSC mode)

4.433619 MHz (PAL mode)

Load Capacitance 16pF

Frequency Tolerance $\pm 30\text{ppm}$

Temperature Characteristics $\pm 30\text{ppm}$

*4. TDK NLT 4532-S3R6B (NTSC mode)

NLT 4532-S4R4 (PAL mode)

Application circuit example

PAL/ $V_{CC2}=12V, V_{EE}=GND$

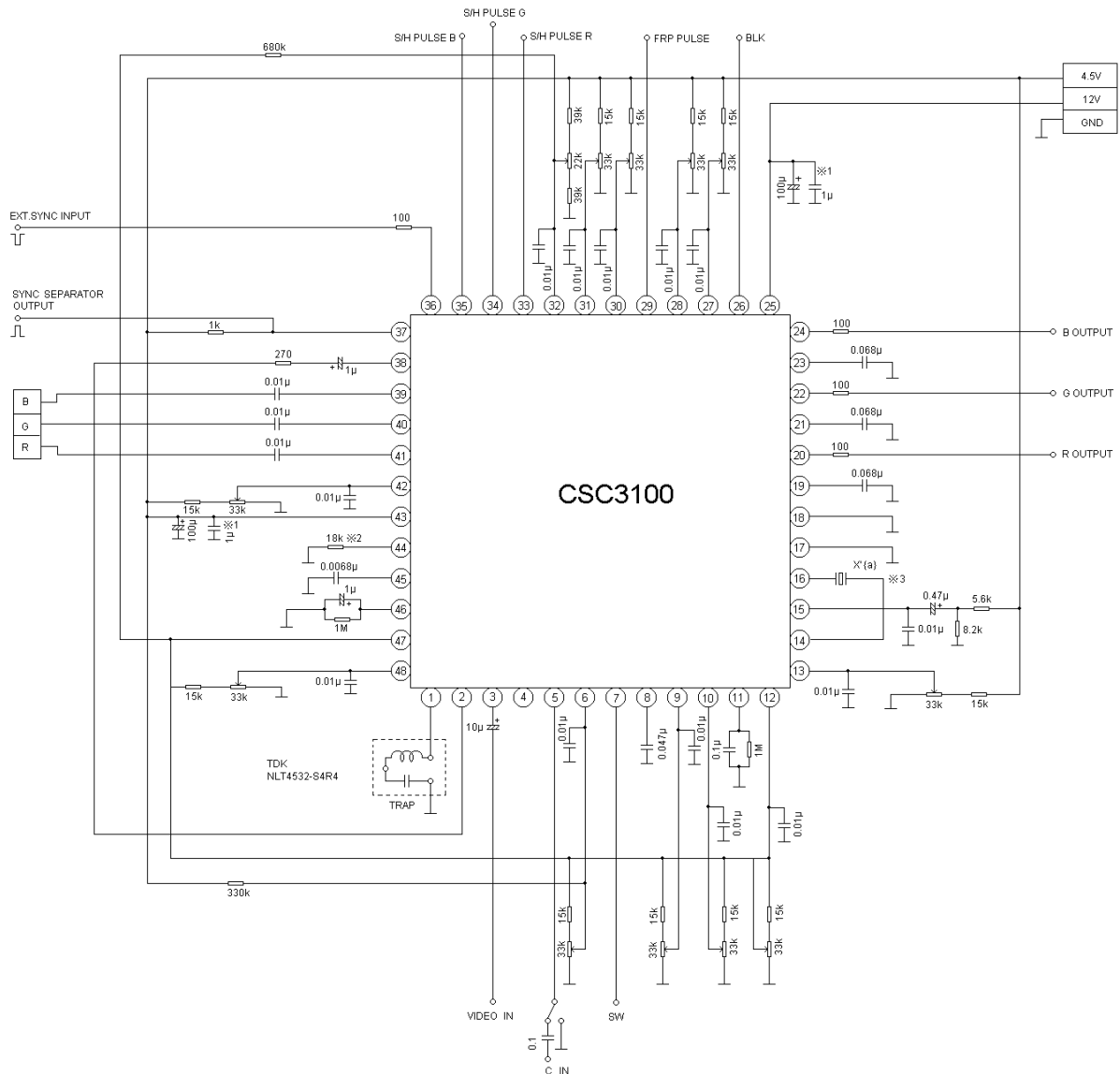

* In the case of composite video signal input mode, connect C IN to GND and input signal to VIDEO IN.

* In the case of Y-C input mode, input luminance signal to VIDEO IN, and chrominance signal to C IN. In this case, TRAP connected to Pin 1 is not necessary.

1 Use ceramic capacitance as decoupling capacitance for a voltage source, and connect it close to the Pin of the IC.

2 Resistance variability: $\pm 2\%$

Temperature characteristics: $\pm 200\text{ppm/}$

3 Daishinku Corporation AT-49

Frequency: 4.433619MHz

Load capacitance 16pF Frequency Tolerance $\pm 30\text{ppm}$

Temperature Characteristics $\pm 30\text{ppm}$

NTSC/V_{CC2}=4.5V, V_{EE} = -7.5V

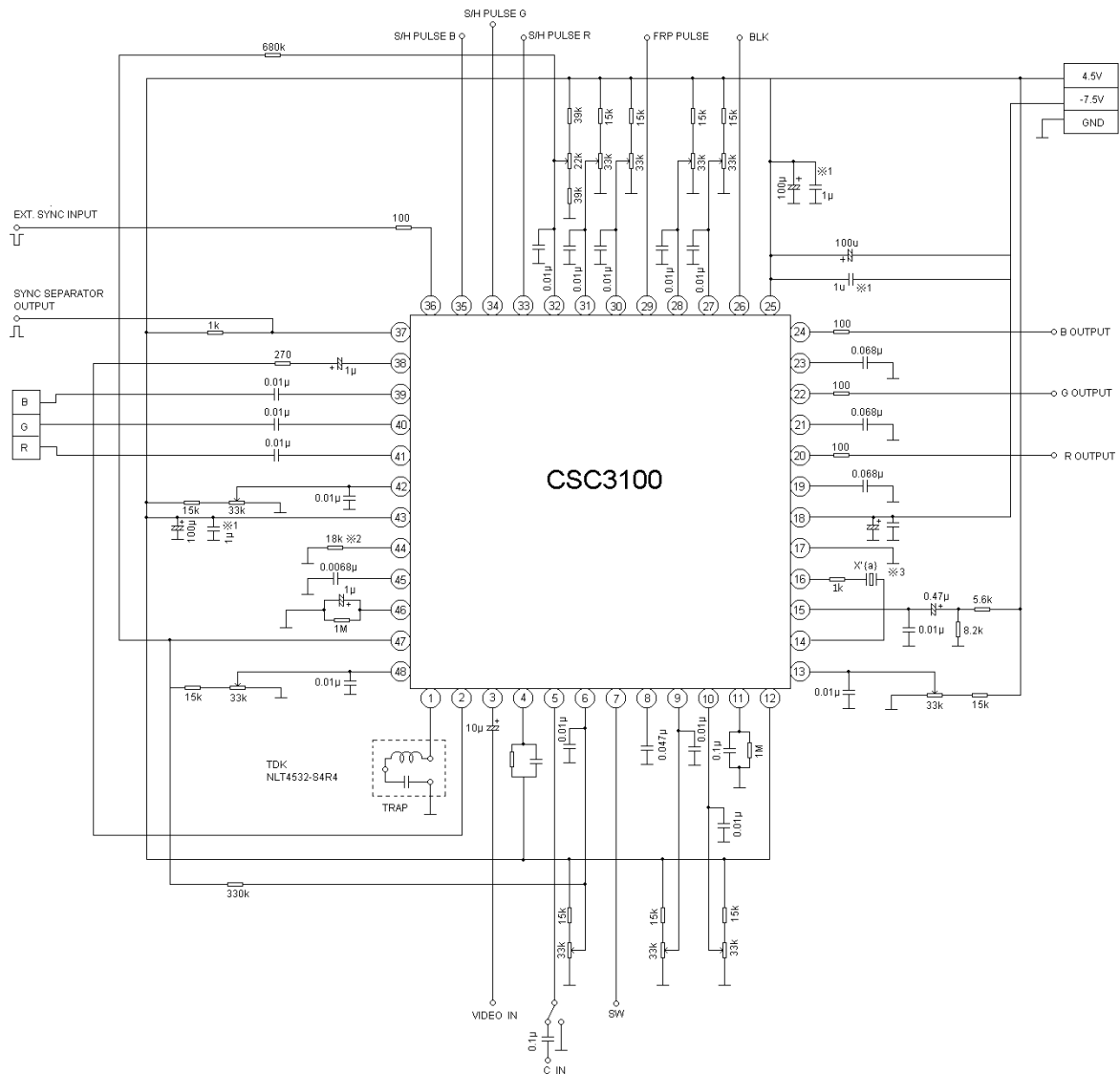

* In the case of composite video signal input mode, connect C IN to GND and input signal to VIDEO IN.

* In the case of Y-C input mode, input luminance signal to VIDEO IN, and chrominance signal to C IN. In this case, TRAP connected to Pin 1 is not necessary.

1 Use ceramic capacitance as decoupling capacitance for a voltage source, and connect it close to the Pin of the IC.

2 Resistance variability: $\pm 2\%$

Temperature characteristics: $\pm 200\text{ppm/}$

3 Daishinku Corporation AT-49

Frequency: 3.579545MHz

Load capacitance 16pF Frequency Tolerance $\pm 30\text{ppm}$

Temperature Characteristics $\pm 30\text{ppm}$