

# DESIGN NOTES

## Ultraprecise Instrumentation Amplifier Makes Robust Thermocouple Interface – Design Note 302

Jon Munson

### Introduction

The versatile and precise LTC<sup>®</sup>2053 instrumentation amplifier provides an excellent platform for robust, low power instrumentation products—as exemplified below by the battery-powered thermocouple amplifier circuit. The LTC2053 offers exceptionally low 10 $\mu$ V maximum input offset along with 116dB typical CMRR and PSRR, a result of a combination of switched capacitor and zero-drift op amp technologies. It is optimized for low voltage supplies from 2.7V to 11V single ended or up to  $\pm$ 5.5V with split supplies. The LTC2053 is ideal for battery-powered instrument applications because of its low 850 $\mu$ A typical current draw. The gain is easily programmed with two resistors, as shown in Figure 1, just like a traditional non-inverting op amp. The LTC2053 also features low 1/f noise and rail-to-rail I/O to maximize dynamic range.

### The Requirements of Thermocouple Amplification

A robust thermocouple amplification circuit must meet several specific requirements. First, a commonly used type K thermocouple develops 40.6 $\mu$ V/ $^{\circ}$ C, and a standard readout scale is 10mV/ $^{\circ}$ C, so a precision amplifier with a nominal gain of 246 is required. Also, thermocouple leads are generally exposed to the electrical noise of an industrial environment so the fully differential input capability of an instrumentation amplifier helps eliminate errors due to common mode noise pickup. Finally, fault protection against accidental contact of the thermocouple to sources of transients or high voltage is needed but the protection cannot compromise accuracy.

The LTC2053 offers features that help meet all of these requirements. It can withstand a 10mA of fault current in any pin so 10k $\Omega$  protection resistors allow  $\pm$ 100V hard faults or Level 4 ESD (8kV contact/15kV air-gap) on the thermocouple junction without damage to the IC. The LTC2053 uses a switched-capacitor input topology, sampling at approximately 2.5kHz. With an internal input sampling capacitance of  $\sim$ 1000pF, the RC transients of the 10k $\Omega$  protection resistors settle within the  $\sim$ 180 $\mu$ s

sampling window so they do not contribute to offset errors as they might with a typical IA.

### A Battery-Powered Thermocouple Amplifier

Figure 2 shows the LTC2053 used in a battery-powered thermocouple amplifier. The circuit is used as a plug-in adapter for common digital multimeters and is completely portable. This circuit employs the LT1025 thermocouple compensator to improve accuracy over a wide range of ambient conditions and is mounted close to the thermocouple connection points for optimal thermal tracking. It precludes the need to temperature stabilize the thermocouple “cold junctions” and removes the accuracy penalty of a static room temperature correction value.

The output of the LT1025 provides a 10mV/ $^{\circ}$ C correction voltage for the ambient temperature difference from 0 $^{\circ}$ C—normally about 250mV at room temperature. The measured probe temperature is the sum of this compensation voltage and the amplified thermocouple voltage. Simple connection of the output of the compensator to the REF input of the LTC2053 is all that is needed to add these two voltages. The only consideration with this configuration is that the correction voltage must be capable of either

LTC and LT are registered trademarks of Linear Technology Corporation.

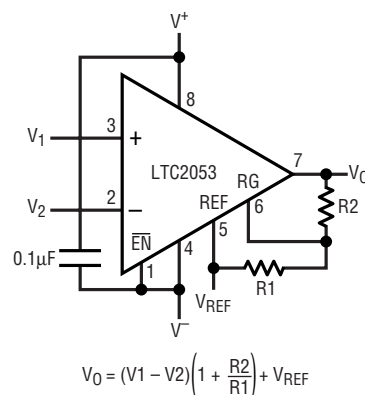

**Figure 1. Typical Connection of LTC2053 Instrumentation Amplifier**

sourcing or sinking the feedback resistor current that flows. As the LT1025 only sources current, a precision buffer can be used to drive the REF node (e.g. using an LTC2050 zero-drift op amp). The limitation imposed by using a single supply is that both the probe and amplifier unit temperatures must be above 0°C for valid output. If negative temperatures must be accommodated, a simple charge-pump inverter, such as an LTC1046, can be used to develop a minus supply rail. The excellent PSRR of the LTC2053 precludes the need for regulated power supplies, and the additional design and space expense they entail. Four AA alkaline cells supply the ICs in this circuit with 3.5V to 5V, depending on state of charge, yielding a minimum full scale output of 350°C. The total battery draw is typically only 1.8mA. In a conventional line-powered application, one can use a single LT1025 and buffer amplifier to correct several LTC2053 thermocouple amplifier channels, provided all the thermocouple connections and the LT1025 thermally track.

### Filtering and Protection

Since the LTC2053 operates by sampling the input signal, the frequencies of interest are generally below a few hundred Hz so it is useful to rolloff the amplifier response by adding 0.1µF in the feedback circuit. The capacitors in the thermocouple input network help absorb RF pickup and suppress sampling artifacts from appearing on the thermocouple leads. The resistors connected to the thermocouple provide a high impedance bias of  $V_S/2$  to maximize common mode immunity without inducing voltage drops in the leads. For short thermocouple lead lengths, which minimize common-mode signals, the probe junction may be grounded (note that with split supplies, grounding would be optimal). The 5.1V Zener is used to provide fault-induced supply overvoltage and reverse-battery protection in conjunction with the 560Ω ballast.

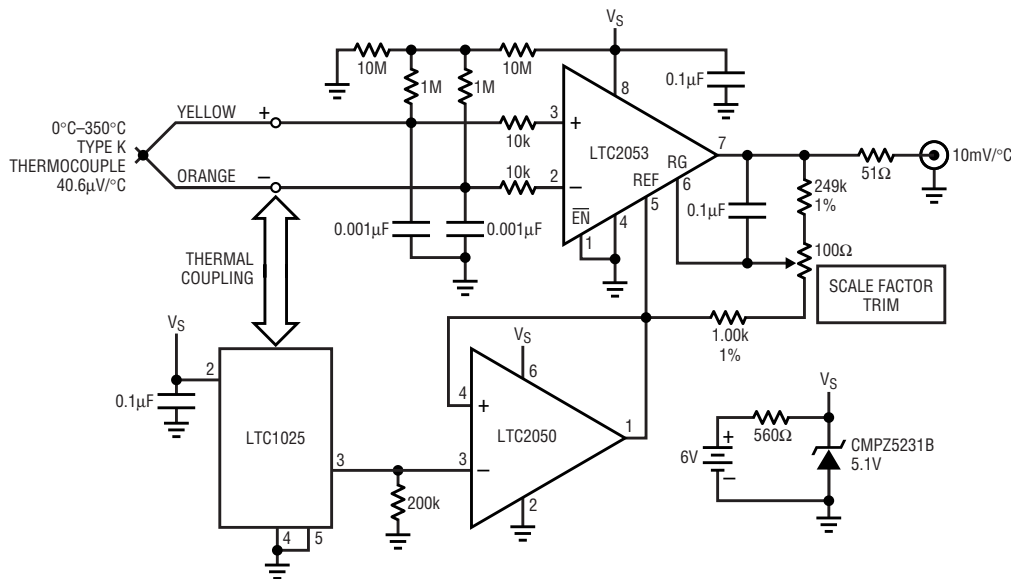

Figure 2. Complete Schematic of the Thermocouple Amplifier

#### Data Sheet Download

<http://www.linear.com/go/dnLTC2053>

For literature on our Instrumentation Amplifiers, call **1-800-4-LINEAR**. For applications help, call (408) 432-1900, Ext. 2156