

F²MC-8L/16LX/FR FAMILY
8/16/32-BIT MICROCONTROLLER
ALL SERIES

OSCILLATOR CIRCUIT
CONFIGURATION
APPLICATION NOTE

Revision History

Date	Issue
14.10.2003	V1.0 First draft
22.12.2003	V1.1 Chapter 3.2 updated
22.04.2004	V1.2 Upgraded, MWi

This document contains 15 pages.

Warranty and Disclaimer

To the maximum extent permitted by applicable law, Fujitsu Microelectronics Europe GmbH restricts its warranties and its liability for **all products delivered free of charge** (eg. software include or header files, application examples, target boards, evaluation boards, engineering samples of IC's etc.), its performance and any consequential damages, on the use of the Product in accordance with (i) the terms of the License Agreement and the Sale and Purchase Agreement under which agreements the Product has been delivered, (ii) the technical descriptions and (iii) all accompanying written materials. In addition, to the maximum extent permitted by applicable law, Fujitsu Microelectronics Europe GmbH disclaims all warranties and liabilities for the performance of the Product and any consequential damages in cases of unauthorised decompiling and/or reverse engineering and/or disassembling. **Note, all these products are intended and must only be used in an evaluation laboratory environment.**

1. Fujitsu Microelectronics Europe GmbH warrants that the Product will perform substantially in accordance with the accompanying written materials for a period of 90 days from the date of receipt by the customer. Concerning the hardware components of the Product, Fujitsu Microelectronics Europe GmbH warrants that the Product will be free from defects in material and workmanship under use and service as specified in the accompanying written materials for a duration of 1 year from the date of receipt by the customer.
2. Should a Product turn out to be defect, Fujitsu Microelectronics Europe GmbH's entire liability and the customer's exclusive remedy shall be, at Fujitsu Microelectronics Europe GmbH's sole discretion, either return of the purchase price and the license fee, or replacement of the Product or parts thereof, if the Product is returned to Fujitsu Microelectronics Europe GmbH in original packing and without further defects resulting from the customer's use or the transport. However, this warranty is excluded if the defect has resulted from an accident not attributable to Fujitsu Microelectronics Europe GmbH, or abuse or misapplication attributable to the customer or any other third party not relating to Fujitsu Microelectronics Europe GmbH.
3. To the maximum extent permitted by applicable law Fujitsu Microelectronics Europe GmbH disclaims all other warranties, whether expressed or implied, in particular, but not limited to, warranties of merchantability and fitness for a particular purpose for which the Product is not designated.
4. To the maximum extent permitted by applicable law, Fujitsu Microelectronics Europe GmbH's and its suppliers' liability is restricted to intention and gross negligence.

NO LIABILITY FOR CONSEQUENTIAL DAMAGES

To the maximum extent permitted by applicable law, in no event shall Fujitsu Microelectronics Europe GmbH and its suppliers be liable for any damages whatsoever (including but without limitation, consequential and/or indirect damages for personal injury, assets of substantial value, loss of profits, interruption of business operation, loss of information, or any other monetary or pecuniary loss) arising from the use of the Product.

Should one of the above stipulations be or become invalid and/or unenforceable, the remaining stipulations shall stay in full effect

Contents

REVISION HISTORY	2
WARRANTY AND DISCLAIMER	3
CONTENTS	4
1 INTRODUCTION	5
2 SIGNAL DESCRIPTION.....	6
2.1 Main Clock Oscillation	6
2.2 Subclock Oscillation	7
3 SELECTION OF CRYSTAL, CERAMIC RESONATOR OR RC OSCILLATION	8
3.1 Introduction	8
3.1.1 General information about crystals and resonators	8
3.2 Selection of Crystal or Resonator	8
3.3 Specification of Crystal or Resonator.....	10
3.4 ROM devices versus Flash devices.....	11
4 PCB-LAYOUT RECOMMENDATIONS	12
4.1 Introduction	12
4.2 General rules for PCB layout design.....	12
4.3 PCB Layout and Design	13
5 SUMMARY AND CONCLUSION	14
5.1 Summary.....	14
5.2 Conclusion	14
6 APPENDIX.....	15

1 Introduction

This application note provides some information and recommendations how to connect external crystals or resonators to Fujitsu microcontrollers. In order to achieve a proper and stable clock oscillation the composition of external circuits, PCB layout design and the microcontroller must be taken into account and evaluated carefully. The selection of the crystal or resonator depends also on the application requirements and environmental conditions. The information here given are general guidelines for reference in order to achieve the best solution for customers and applications requirements. Because specific restrictions of a dedicated microcontroller series might exist, it is necessary to check additionally the corresponding datasheet and hardware manual of the microcontroller series.

2 Signal Description

The dedicated clock signals are described

2.1 Main Clock Oscillation

Generally all MCUs offer connection of a main clock oscillation. The dedicated pins for main clock connection are X0, X1. If an external clock generator is used it will be connected to X0, X1 will be NC in this case. Special restrictions regarding the oscillation frequency range might exist depending on whether a crystal oscillator or an external clock oscillator is used. Corresponding specifications are listed in the datasheet of the selected microcontroller series. To ensure proper operation always check the description about how to connect and use external clock supply in the corresponding datasheet and hardware manual of the microcontroller series.

The following figure shows the general connection for the main clock crystal connection.

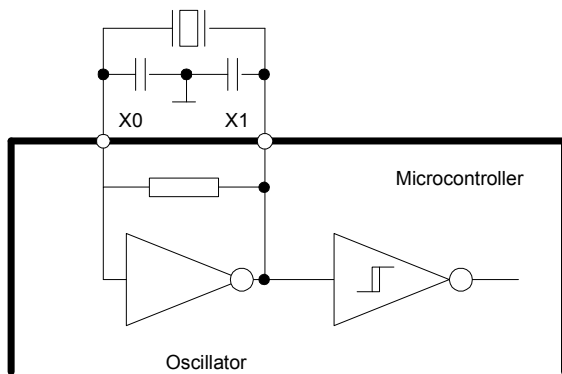

Figure2-1. General main crystal connection

The following figure shows the general connection for an external main clock oscillator.

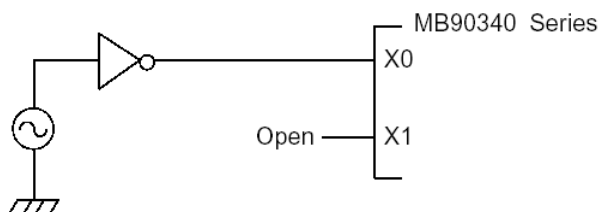

Figure2-2. General main clock oscillator connection

2.2 Subclock Oscillation

Some microcontrollers offer additionally the connection of a low frequency subclock. The dedicated pins for subclock connection are X0A and X1A. The frequency range for the subclock is specified in the corresponding microcontroller datasheet. Device specific restrictions and frequency ranges might exist and must be considered.

The following figure shows the general connection for the subclock connection.

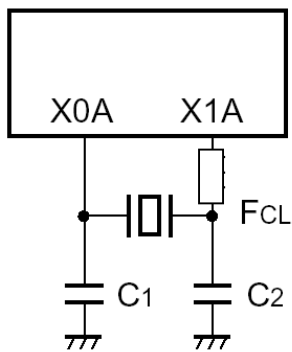

Figure2-3. General subclock crystal connection

3 Selection of Crystal, Ceramic Resonator or RC Oscillation

Recommendations how to select and configure the external oscillation source

3.1 Introduction

For Fujitsu microcontrollers generally crystals and ceramic resonators can be used for the main clock oscillator. So far, RC-oscillation is generally not supported by 16LX and FR series but might be supported with future series. Currently just some specific series within the F²MC-8L family support RC-oscillation. Corresponding recommended RC values can be found in the adequate datasheets.

For subclock oscillation only the usage of crystals is supported. Ceramic resonators are generally not available for lower frequencies of 100KHz or less.

3.1.1 General information about crystals and resonators

The choice of oscillator type used in an application depends on the accuracy required. For high precision oscillation e.g. CAN network applications normally crystals are recommended or special high precision resonators. Additionally the environmental influences like temperature range must be taken into account. Mostly all manufacturers of crystals and resonators are offering optimised solutions for e.g. automotive or telecom applications to fulfil application specific requirements.

General differences between crystal and resonators are listed in the following table. The table is not referencing to any dedicated crystal or resonator type or manufacturer. Of course versatile types of resonators or crystals exist on the market exceeding the here listed features.

	Ceramic Resonator	Crystal Resonator
Aging	+/- 3000ppm/year	+/- 10ppm/year
Frequency Tolerance	+/- 2000 – 5000ppm	+/- 10ppm - +/- 50ppm
Oscillator Rise Time	0.01 – 0.5ms	1- 10ms
Quality Factor	100 - 5000	10 ³ - 10 ⁵

Table 3-1 General Features of Crystals and Resonators

3.2 Selection of Crystal or Resonator

All devices of e.g. the F²MC-16LX family offer connection of a main clock oscillation which normally is in the range of 3-24MHz. But this specification depends on the selected microcontroller series. The minimum and maximum values for the specified frequency range of the external oscillation or clock supply should always carefully be checked with the datasheet of the corresponding microcontroller series.

When using crystals or resonators a capacitive load must be applied externally (some crystals/resonators types offer integrated capacitors) according to the requirements of the chosen resonator/crystal. A parallel resonator will not oscillate with a stable oscillation, if the capacitive load is insufficient. Higher capacitive load normally offers more stable oscillation. On the other side, if the capacitive load is too high, the oscillation may have problems to start the oscillation due to drive level dependency of the load. So the selection of the

appropriate capacitive load is the solution for proper accurate clock oscillation. Additionally external capacitors might influence the operating clock frequency of the crystal, which must be considered as well. Depending on the selected crystal/resonator an additional external resistor might be recommended in order to tune the drive level to the needs of the oscillator type.

The capacitive load C_L of the oscillator circuit, including stray capacitances like the capacitance of the X0, X1 or X0A, X1A of the microcontroller pins, MCU socket, PCB layout, can be calculated by the equation:

$$C_L = (C_{L1} * C_{L2}) / (C_{L1} + C_{L2}) + C_s$$

In this equation C_{L1} and C_{L2} refer to the external capacitors shown in figure 2-1. C_s is the summarised stray capacitance. C_s can be estimated for most designs to 5pF – 10pF, but even higher values might exist. If $C_{L1} = C_{L2} = C_L$ the equation for C_{L1} , C_{L2} can be simplified to:

$$C_{L1} = C_{L2} = 2*(C_L - C_s)$$

Fujitsu recommends as a reasonable first choice for $C_{L1} = C_{L2} = 22\text{pF}$ to 33pF . The value can vary depending on the selected crystal type. These capacitors should be connected between X0/X1 (X0A/X1A) and GND as shown in figure 2-1 and figure 2-3. As the crystal and resonator oscillation stability and accuracy is a very sensitive topic, Fujitsu is in close contact with the main oscillation clock suppliers in order to provide reasonable values for the external components. So for versatile microcontrollers dedicated crystal/resonator measurements of the suppliers are available and can be provided to customers. For some microcontrollers some information can be found in the datasheet, which are for reference only.

The recommendations will work well in most applications, however there is no way to provide general values of the external oscillator components that can guarantee proper operation with all types of crystal and resonators. Especially application specific PCB layout configurations can influence these values very much. For this reason special tests and specifications using the original application are offered by crystal/resonator manufacturers.

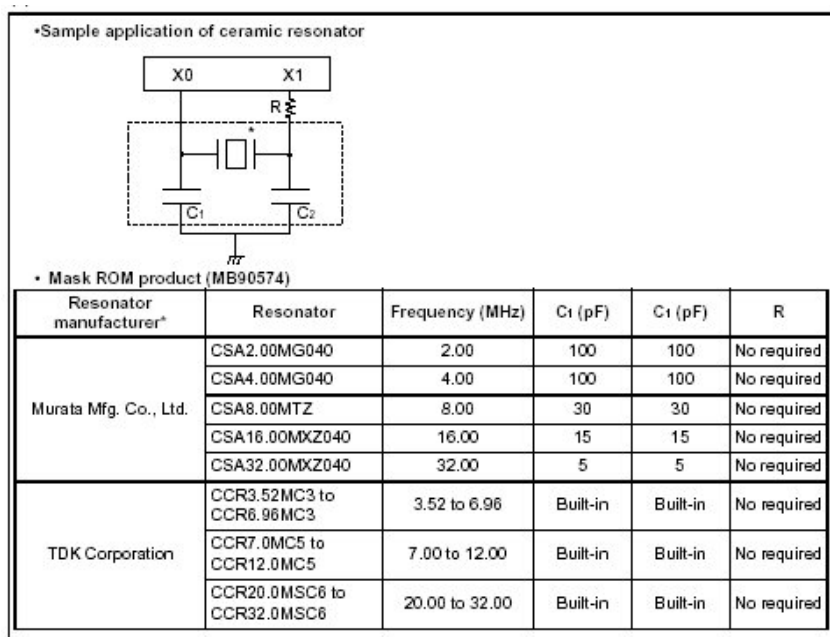

Figure 3-1 Example of recommended resonators listed in the datasheet of MB90570 series

3.3 Specification of Crystal or Resonator

The description in chapter 3.2 is a first step to select a suitable crystal/resonator configuration. This configuration will work in most applications and environments but there is no way of specifying general values which always will work. Especially PCB layout and temperature requirements of the application are influencing the parameters. So dedicated tests are highly recommended and are offered by all crystal and resonators manufacturers. In order to perform these kind of tests customer offer the PCB of their application and the crystal/resonator manufacturer is performing the tests with the customers application board. This ensures proper and accurate function of the original system configuration, taking into account the environmental conditions the tests are performed for.

Fujitsu is in close contact with main crystal/resonator manufacturers e.g. KDS Daishinku, Kinseki Limited, Murata, NDK, Telequarz, etc. Adequate reference measurements and reports are available for most microcontrollers or will be done on special request. In case of need please contact Fujitsu or your preferred crystal/resonator manufacturer to get the required reports.

The following figures show the crystal test and specification report of Kinseki Limited for MB90F387S as an example.

Specification			
IC number:	MB90F387S 0252 M12		
Crystal unit type:	HC-49/U-S		
Frequency:	4000kHz,	8000kHz,	16000kHz
Frequency room-temperature tolerance:	$\pm 50 \times 10^{-6}$ ($25 \pm 5^\circ\text{C}$)		
Frequency temperature characteristics (referred to 25°C):	$\pm 200 \times 10^{-6}$ ($-40 \sim +105.25^\circ\text{C}$)		
Resonance resistance standard:	200 Ω MAX.	90 Ω MAX.	50 Ω MAX.
Load capacitance:	8pF		
Circuit examination history			
Aug.7.2003 K1502-03C76-211 1/2~2/2 : First Edition			

○ 4000kHz, 8000kHz, 16000kHz measuring circuit diagram (Universal board)

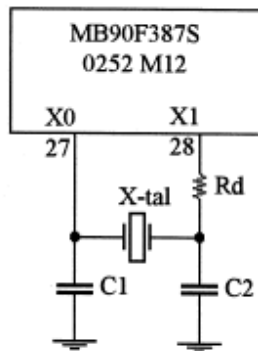

Vdd = 5V
 X-tal: HC-49/U-S
 4000 kHz (Load capacitance=8pF)
 8000 kHz (Load capacitance=8pF)
 16000 kHz (Load capacitance=8pF)
 Measuring frequency: 4,8,16 MHz

- Measuring equipment
 - Negative resistance: frequency: Spectrum analyzer (Anritsu MS2661C)
 - Start-up time: Oscilloscope (HP Infinium 500MHz)
Probe (HP1152A)
 - Drive current: Oscilloscope (HP Infinium 500MHz)
Probe (TEKTRONIX P6022A)
- Common measuring items (characteristics when at recommending constants)
 - Measuring items: Negative resistance, load capacitance, frequency tolerance, drive level, $3F_0$ negative resistance, start-up time.

○ Circuit constants and characteristics

Frequency (MHz)	Circuit constants	Negative resistance (Ω)	Load capacitance (pF) *1	Frequency tolerance ($\times 10^{-6}$) *2	Drive level (μ W) *3	$3F_0$ negative resistance (Ω)	Start-up time (ms)
4000	Rd=0 Ω C1=9pF C2=9pF	-5455	8.09	-1.8	42.8	-653 (at 12MHz)	2.1
8000	Rd=0 Ω C1=10pF C2=9pF	-1224	8.00	+0.1	59.1	-145 (at 24MHz)	1.2
16000	Rd=0 Ω C1=10pF C2=9pF	-349	7.80	+7.9	162.0	-0 (at 48MHz)	1.1

- *1 Load capacitance of oscillator circuits.
- *2 Frequency tolerance when it is presumed that a crystal unit produced to have frequency tolerance = ± 0 at load capacitance = 8pF is used.
- *3 When a crystal unit series resonance resistance (4000kHz:38.53 Ω , 8000kHz:14.97 Ω , 16000kHz:10.6 Ω) is used.

○ About frequency range

Since negative resistance is small in order to use by the 16MHz frequency band, it cannot recommend. However, since negative resistance will become large if C1 and C2 are changed into small value when it is permitted that a frequency deviation becomes large to high value, it may be able to use.

3.4 ROM devices versus Flash devices

Note, that the technology of Mask-ROM and Flash Devices is different. Therefore the crystal tests have to be done for each technology. As a result, the crystal type can differ for a ROM derivatives of a Flash device and vice versa!

4 PCB-Layout Recommendations

Recommendations for PCB layout to connect crystal/resonator oscillator

4.1 Introduction

Based on the example for the 16LX family PCB layout rules and recommendations are shown hereafter. In principle the same recommendations are valid for FFMC-8L and FR series. For further layout design rules please also check the application note *EMC Design Guide F²MC-16LX Family*.

4.2 General rules for PCB layout design

1. Use max. trace-width and min. length to connect VSS and VDD μ C-pins to decoupling capacitors (DeCap)
2. Don't use stub line to connect the DeCap to μ C-pins, let flows the noise current direct through pads of DeCap
3. Use close ground plane direct below MCU package as shield
4. Use different ground systems for analogue, digital, power-driver and connector ground
5. Avoid loop current in the ground system, check for ground loops.
6. Use a star point ground below MCU for analogue and digital ground, use a second star point ground below 5V regulator for MCU, power-driver and connector ground
7. Don't create signal loop on the PCB, minimize trace length
8. Partitione system into analogue, digital and power-driver section
9. Place series resistor or RC-block for the IO-circuit nearby MCU-pin to reduce the noise on the signal line.
10. Use a capacitor for each connector pin to reduce the noise of external lines, place this capacitor close to connector pin

Figure 4-1 shows the oscillator for the Fujitsu 16-bit family. For best performance, the PCB layout of this circuit should cover only a very small area. For the layout is recommended a PCB with two or more layers. Make sure to provide bypass capacitors via shortest distance from X0, X1 pins, crystal oscillator, and ground lines. The lines of the oscillation circuit should not cross lines of other circuits.

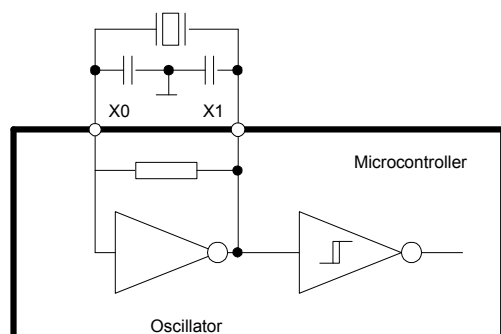
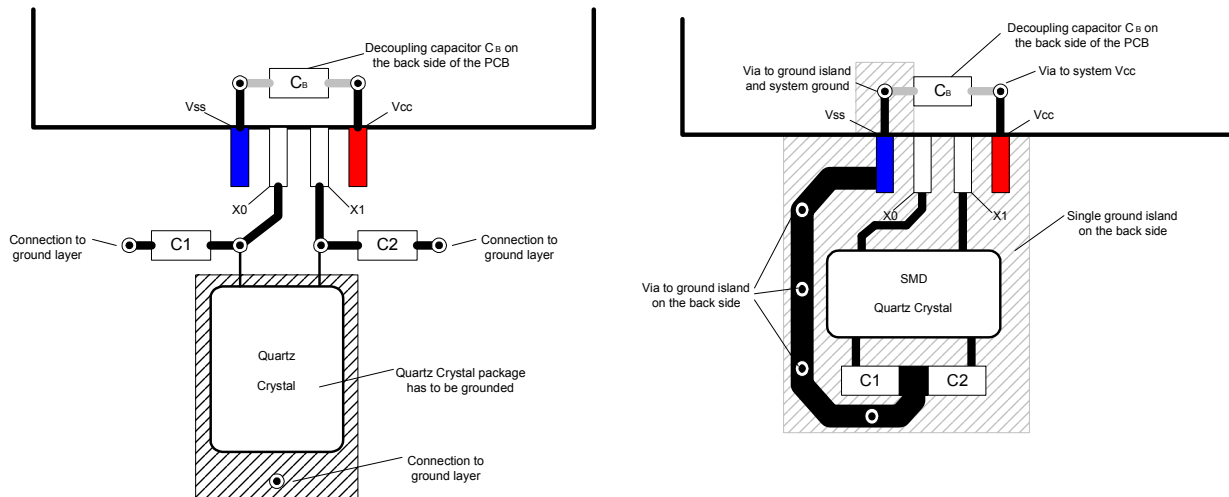

Figure 4-1 Principle of main crystal clock oscillator

4.3 PCB Layout and Design

It is necessary to avoid coupling noise into the power supply of the clock circuit.

The crystal oscillator has to be connected with short lines to X0/X1(X0A/X1A) and Vss. Note that pin X1 (X1A) is the output of inverter. Particularly this track should have a short length.



a) Layout example for a leaded quartz crystal
 Worse layout design, because C1 and C2
 are wrongly connected to VSS

b) Layout example for a SMD quartz crystal
 Better layout design, because C1 and
 are connected to V_{ss} and then after with
 the system ground

Figure 5-1 Layout example for oscillator circuit

Please also have a look at the Application Note *AN-900098-HW_SETUP* for further layout recommendations.

5 Summary and Conclusion

Final conclusion about selection of suitable resonators/crystals

5.1 Summary

This application note is giving guidelines and recommendations for the circuit composition and configuration of the oscillation clock source for Fujitsu microcontrollers. In general it is impossible to offer general values and specifications for the oscillation which will work under all environmental and application requirements. Additionally the PCB layout and PCB material is influencing this specification. For this reasons just reference values can be offered which work in most cases but do not consider worst case scenarios of e.g. temperature, additional capacitive load on the PCB.

5.2 Conclusion

For the specification of a crystal or resonator clock source including the specification of the needed external components it is mandatory, especially for high precision systems and systems requiring highest reliability, to perform application specific measurements. These measurements are done in cooperation with crystal/resonator manufactures offering this kind of service. For this purpose Fujitsu is in close contact will the main manufacturers of crystal/resonators.

This application note is giving design rules and recommendations for the composition of the oscillation clock source which will work in most applications but they do not release the system designer from a verification in the original system. The final qualification has to be done by the customer with his special PCB.

6 Appendix

- END –