

EMC Design Guide

F²MC-8L Family

© Fujitsu Mikroelektronik GmbH, Microcontroller Application Group

History

04 th Jul 02	NFL	V1.0	Initial draft
18 th Jul. 02	NFI	V1.1	Description DeCap added

Warranty and Disclaimer

To the maximum extent permitted by applicable law, Fujitsu Mikroelektronik GmbH restricts its warranties and its liability for **all products delivered free of charge** (eg. software include or header files, application examples, application Notes, target boards, evaluation boards, engineering samples of IC's etc.), its performance and any consequential damages, on the use of the Product in accordance with (i) the terms of the License Agreement and the Sale and Purchase Agreement under which agreements the Product has been delivered, (ii) the technical descriptions and (iii) all accompanying written materials. In addition, to the maximum extent permitted by applicable law, Fujitsu Mikroelektronik GmbH disclaims all warranties and liabilities for the performance of the Product and any consequential damages in cases of unauthorised decompiling and/or reverse engineering and/or disassembling. **Note, all these products are intended and must only be used in an evaluation laboratory environment.**

1. Fujitsu Mikroelektronik GmbH warrants that the Product will perform substantially in accordance with the accompanying written materials for a period of 90 days from the date of receipt by the customer. Concerning the hardware components of the Product, Fujitsu Mikroelektronik GmbH warrants that the Product will be free from defects in material and workmanship under use and service as specified in the accompanying written materials for a duration of 1 year from the date of receipt by the customer.
2. Should a Product turn out to be defect, Fujitsu Mikroelektronik GmbH's entire liability and the customer's exclusive remedy shall be, at Fujitsu Mikroelektronik GmbH's sole discretion, either return of the purchase price and the license fee, or replacement of the Product or parts thereof, if the Product is returned to Fujitsu Mikroelektronik GmbH in original packing and without further defects resulting from the customer's use or the transport. However, this warranty is excluded if the defect has resulted from an accident not attributable to Fujitsu Mikroelektronik GmbH, or abuse or misapplication attributable to the customer or any other third party not relating to Fujitsu Mikroelektronik GmbH.
3. To the maximum extent permitted by applicable law Fujitsu Mikroelektronik GmbH disclaims all other warranties, whether expressed or implied, in particular, but not limited to, warranties of merchantability and fitness for a particular purpose for which the Product is not designated.
4. To the maximum extent permitted by applicable law, Fujitsu Mikroelektronik GmbH's and its suppliers' liability is restricted to intention and gross negligence.

NO LIABILITY FOR CONSEQUENTIAL DAMAGES

To the maximum extent permitted by applicable law, in no event shall Fujitsu Mikroelektronik GmbH and its suppliers be liable for any damages whatsoever (including but without limitation, consequential and/or indirect damages for personal injury, assets of substantial value, loss of profits, interruption of business operation, loss of information, or any other monetary or pecuniary loss) arising from the use of the Product.

Should one of the above stipulations be or become invalid and/or unenforceable, the remaining stipulations shall stay in full effect.

Table of Contents:

1	INTRODUCTION	4
2	RULES TO CREATE A GOOD LAYOUT	4
3	CRYSTAL OSCILLATOR CIRCUIT	5
4	POWER SUPPLY ROUTING	6
5	NOISE REDUCTION FOR GENERAL IO PINS	9
6	FUNCTION OF CERTAIN MCU PINS	9
7	EMI MEASUREMENT FOR F²MC-8L FAMILY	10
7.1	Measurement setup	10
7.2	Measurement procedure	10
7.3	Measurements	10
7.4	Blank check	11
7.5	Noise measurements on VCC	11

1 Introduction

In the following description, the EMC design guide of 8-bit Fujitsu microcontroller will be discussed. It describes how external power supply should be connected to the Vcc and Vss pins and offers some suggestions. An overview of internal supply of MCU is made as well to have a better understanding of the design. The EMI measurements in the following described tests are just example measurements. The measured emissions are no data, which are specified in the DS of the microcontroller series.

During the last designs the EMI of the Fujitsu F²MC-8L microcontroller series could be reduced step by step. The PLL multiplier circuit allows the usage of low crystal frequency to reduce high-frequency noise from the oscillator circuit.

The clock tree is mostly the cause of the noise. Therefore the driver capability of clock buffers is optimised and for one big buffer are used several small clock buffers.

The integration of On-chip bypass capacitors reduces the noise ripple on the internal power supply net so that the broadband noise on the IO pins is improved.

The following description is based on the MB89530 series, but the same situation exists for all current devices of the F²MC-8L family, with or without an external bus interface.

2 Rules to create a good Layout

1. Use max. trace-width and min. length to connect VSS and VDD μ C-pins to decoupling capacitors (DeCap)
2. Don't use stub line to connect the DeCap to μ C-pins, let flows the noise current direct through pads of DeCap
3. Use close ground plane direct below MCU package as shield
4. Use different ground systems for analogue, digital, power-driver and connector ground
5. Avoid loop current in the ground system, check for ground loops.
6. Use a star point ground below MCU for analogue and digital ground, use a second star point ground below 5V regulator for MCU, power-driver and connector ground
7. Don't create signal loop on the PCB, minimize trace length
8. Partitioned system into analogue, digital and power-driver section
9. Place series resistor or RC-block for the IO-circuit nearby MCU-pin to reduce the noise on the signal line.
10. Use a capacitor for each connector pin to reduce the noise of external lines, place this capacitor close to connector pin

3 Crystal Oscillator Circuit

Figure 1 shows the oscillator for the 8-bit family. For best performance, the PCB layout of this circuit should cover only a very small area. For the layout is recommended a PCB with two or more layers. Make sure to provide bypass capacitors via shortest distance from X0, X1 pins, crystal oscillator, and ground lines. The lines of the oscillation circuit should not cross lines of other circuits.

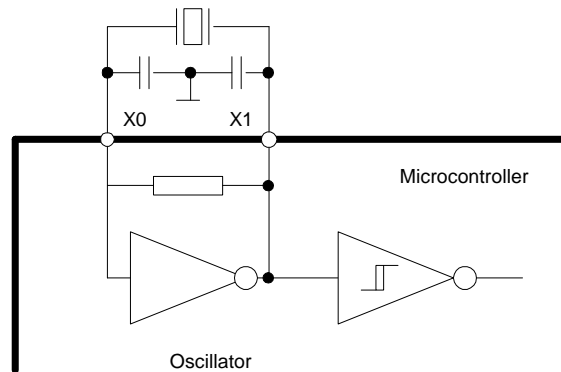
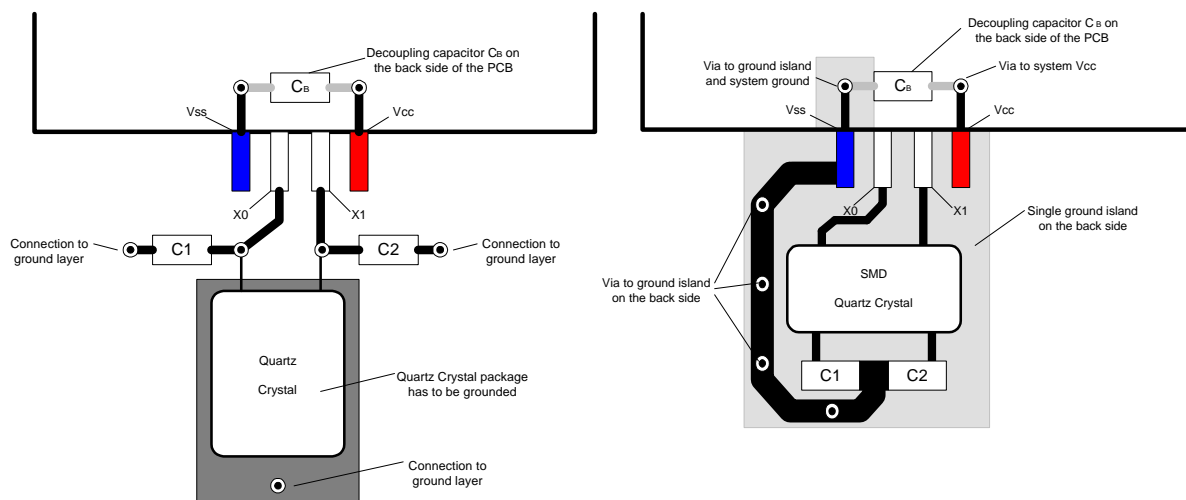

Figure 1: Principle of the Oscillator circuit

It is necessary to avoid coupling noise into the power supply (pin 81/84) of the clock circuit. The crystal oscillator has to be connected with short lines to X0/X1 and Vss. Note that pin X1 is the output of inverter. Particularly this track should have a short length.



a) Layout example for a leaded quartz crystal worse layout design, because C1 and C2 are wrong connected to VSS

b) Layout example for a SMD quartz crystal better layout design, because C1 and C2 are connected to Vss and then after with the system ground

Figure 2: Layout example for oscillator circuit

4 Power supply routing

One topic our noise reduction technology is the bypass capacitors. By placing of modules inside the chip, it is possible to connect a bypass capacitor with low impedance where power supply lines are short, effectively reducing the noise to very low flow levels. These bypass capacitors are place into power supply of IO and logic.

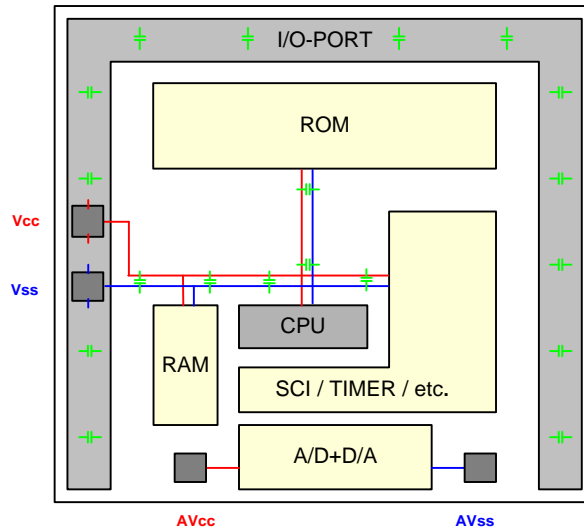

Figure 3: Structure of power supply for MCU core and IO-Port

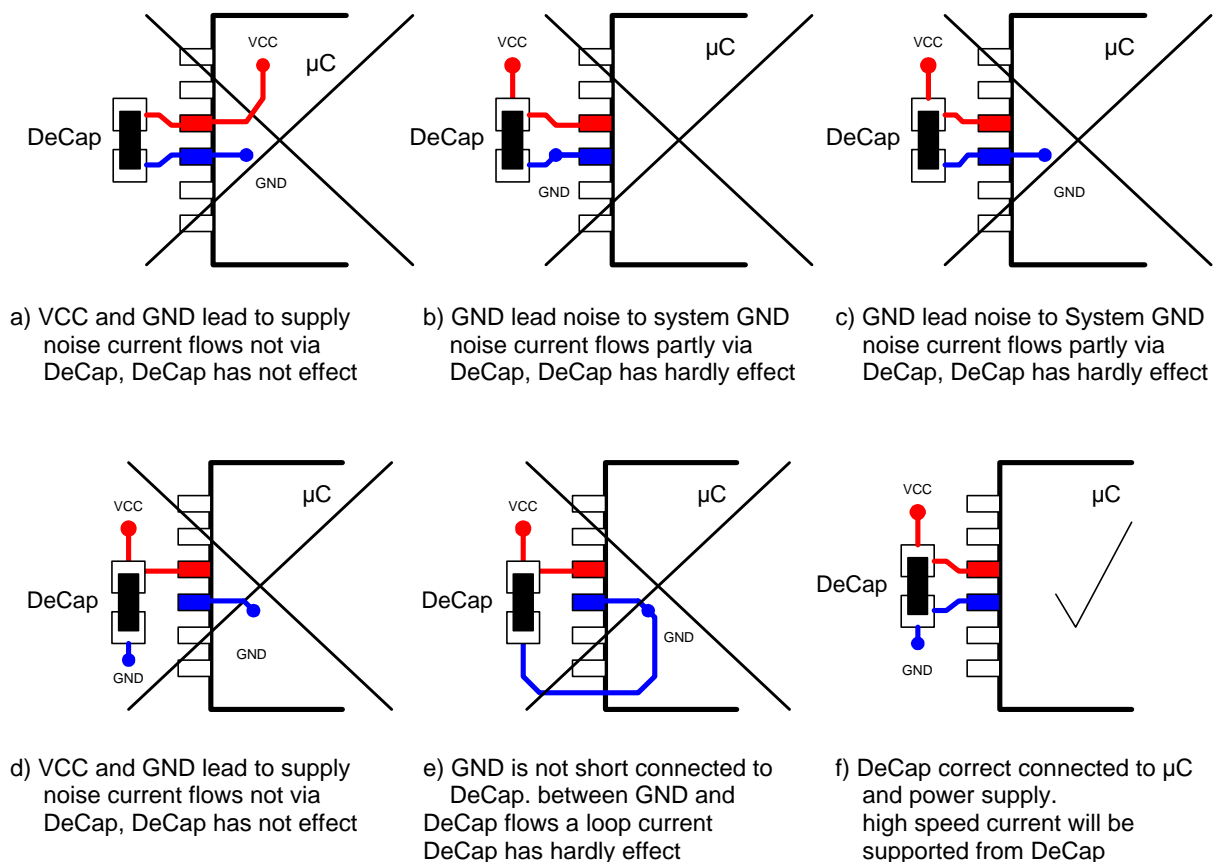

Figure 4: The exactly use of the DeCap (decoupling capacitor)

The high-speed current (di/dt) will be supported from the decoupling capacitor only. Therefore use traces with max. width and min. length between V_{ss}/V_{cc} pin and DeCap. After DeCap use thin traces to route the trace to the power supply system.

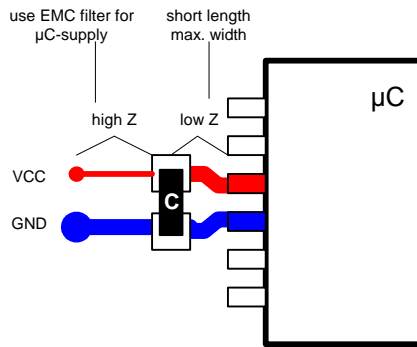

Figure 5: The noise current flows return over the ground line

The exactly use of decoupling capacitors for the V_{cc} and V_{ss} pins is the basis to reduce the noise, but also the return way between load and MCU ground is not neglect.

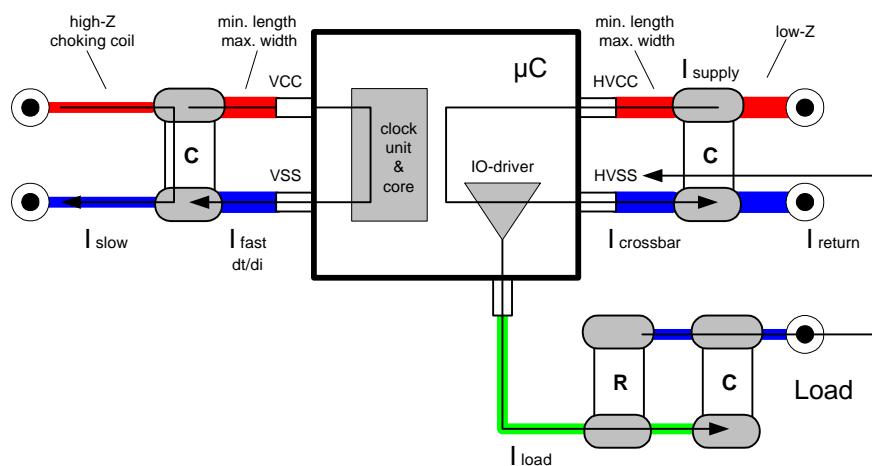

Figure 6: The noise current flows return over the ground line

To ensure an efficient decoupling of the power supply, two capacitors should be placed close on each V_{cc} pin. The values of both capacitors should have a relationship of about 1:100. Typical values are e.g. 100nF (XR7) and 1nF (COG). The accurate value is depended on the application board, e.g. impedance of PCB or the length of supply lines. However, all of the DeCaps on the PCB should have the same value.

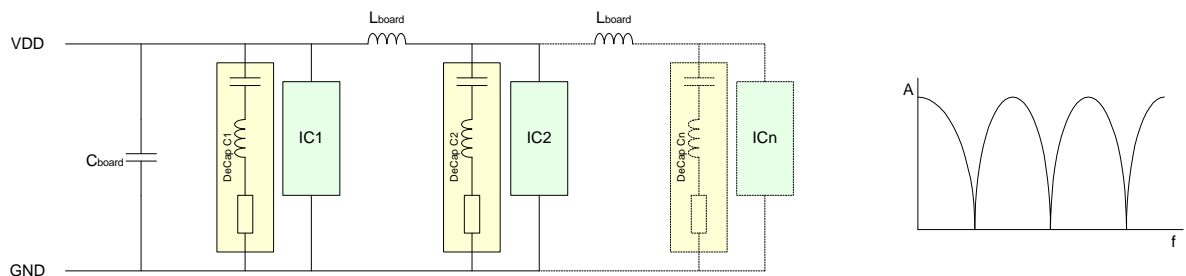

Figure 7: The use of several values of DeCaps lead to undefined resonance frequencies, that's why all DeCaps should have the same value.

For 2-layer boards should be used a closed ground plane (located directly below the MCU). The Vcc supplies should be taken from the bottom layer.

For 4-layer boards should be used the inside layers for GND and Vcc supplies. In this case, both layers form additional capacitor (broadband behaviour) for the power supply.

Figure 8 shows a layout example for the connection of powers supply on the MCU. This method of Vcc connection reduces the loop of the Vcc around the MCU, thus reducing noise emission. A variation of this circuit may be needed, if separate filtered supply voltages are routed to the A/D supplies (pin AVCC/AVSS).

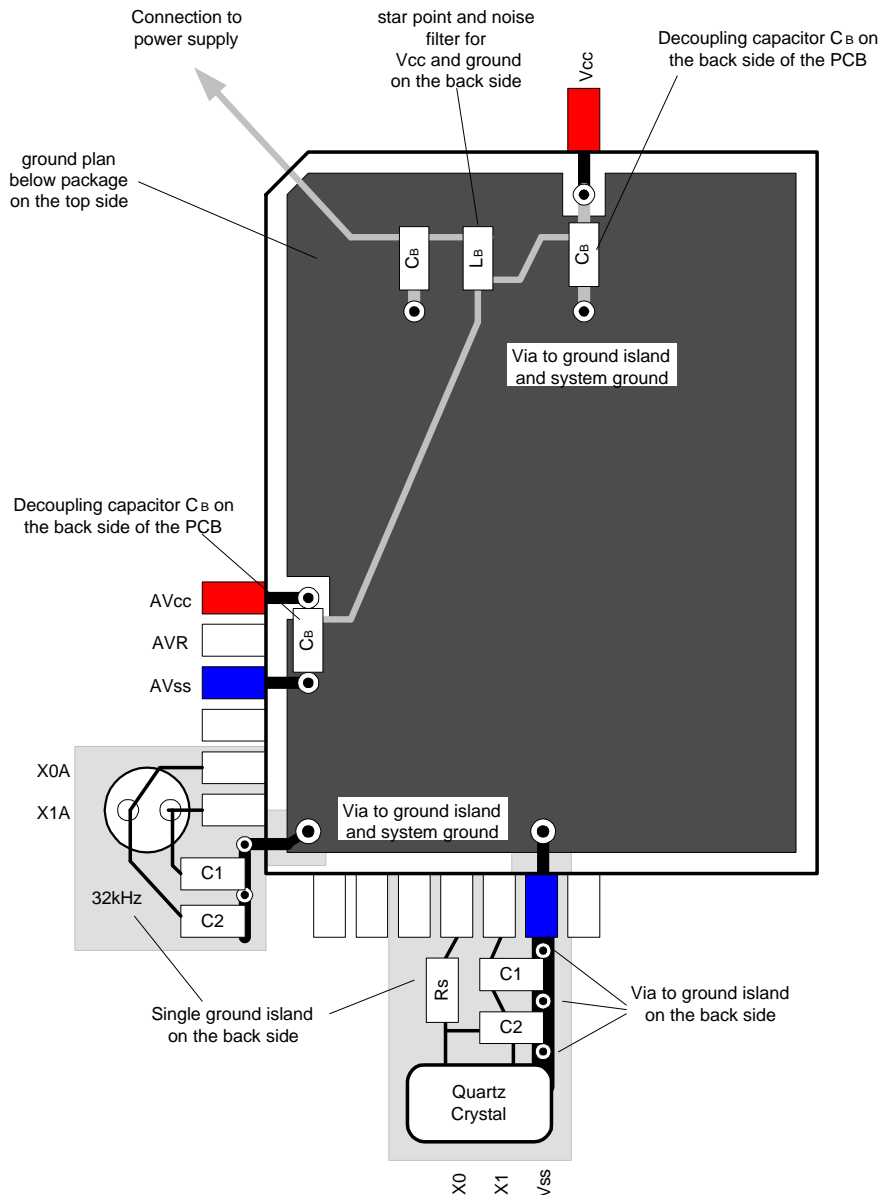

Figure 8: F²MC-8L family with main- and subclock, recommended layout for multiple layers PCB

Note: All decoupling capacitors on the Vcc pins should have the same value. These capacitors should be placed close to the Vcc pin. The Vcc/Vss current should flows through the pad of the capacitor.

5 Noise reduction for general IO pins

To reduce noise, make sure to connect the Vss or Vcc with smoothed power supply, because the noise on the power supply will also distributed via IO-pin, which is configured as static low or high output. Figure 9 shows an example to reduce the noise on output lines.

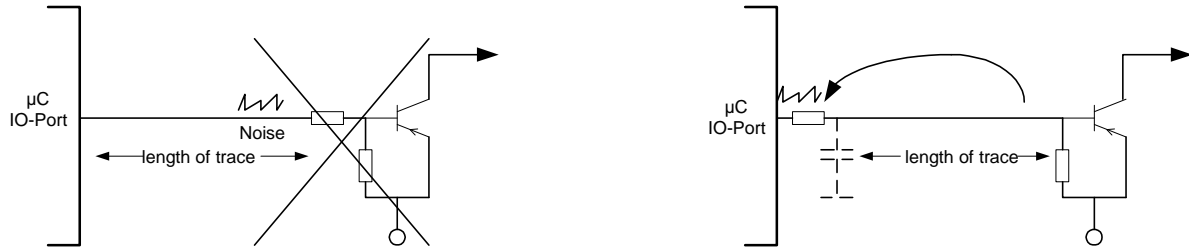

Figure 9: Place the series resistor close to IO pin because so will be reduced the noise of output

Note: To reduce noise, make sure to connect unused input pins to Vss or Vcc (Use pull-down or pull-up resistor, please check the DS of the microcontroller series). Also, especially if CMOS Logic is used, floating gates could generate problems regarding high input currents and latch up.

6 Function of certain MCU pins

Pin name	Function
VDD	Main supply for IO buffer and MCU core
VSS	Main supply for IO buffer and MCU core close to crystal oscillator
AVCC	Power supply for the A/D converter
AVR	Reference voltage input for the A/D converter
AVSS	Power supply for the A/D converter
X0 X0A	Oscillator input, if not used so shall be connected with pull-up or pull-down resistor (see please DS)
X1 X1A	Oscillator output, the crystal and bypass capacitor must be connected via shortest distance with X1 pin, if not used so shall be open

7 EMI Measurement for F²MC-8L family

7.1 Measurement setup

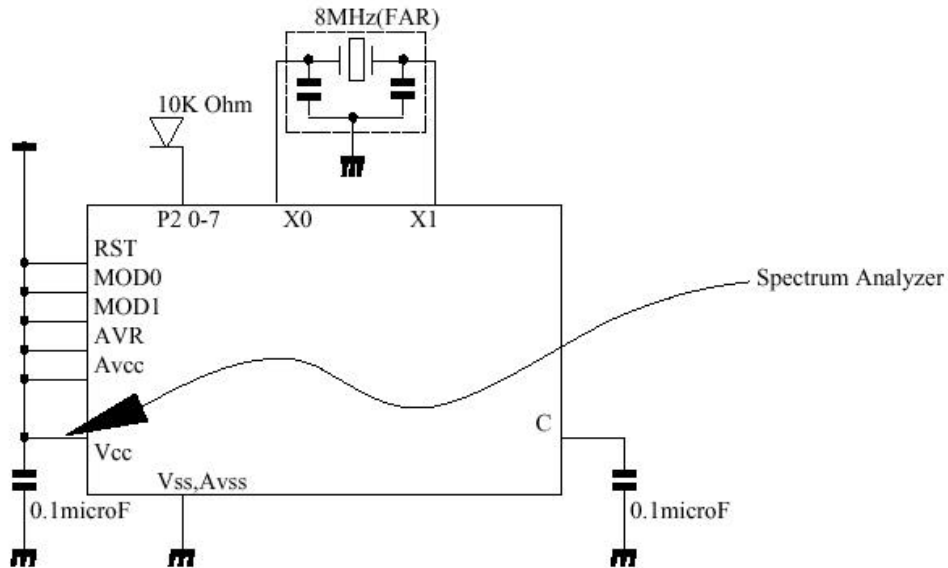

Figure 10: Set-up for noise measurement on power supply

7.2 Measurement procedure

- RF- voltage, measured on VCC power supply by BI mode RUN
- RF- voltage, measured on VCC power supply by BI mode RESET

7.3 Measurements

Sample: MB89538A, MB89538AL, MB89535A

Measurement condition: Ta = 25 deg.C

Power supply: Vcc = 5.0V / 3.0V

Crystal: 8MHz (FAR)

Frequency range: 0MHz to 120MHz, BW: 120kHz

7.4 Blank check

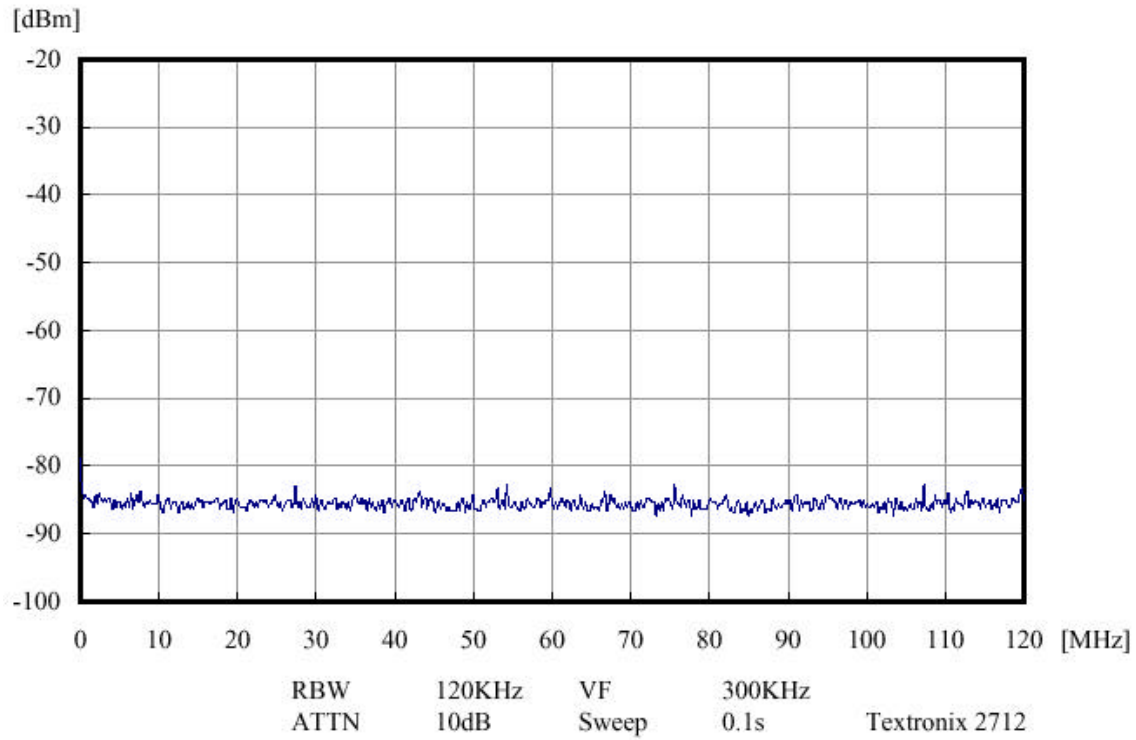

Figure 11: Noise measured on VCC power supply, blank check

7.5 Noise measurements on VCC

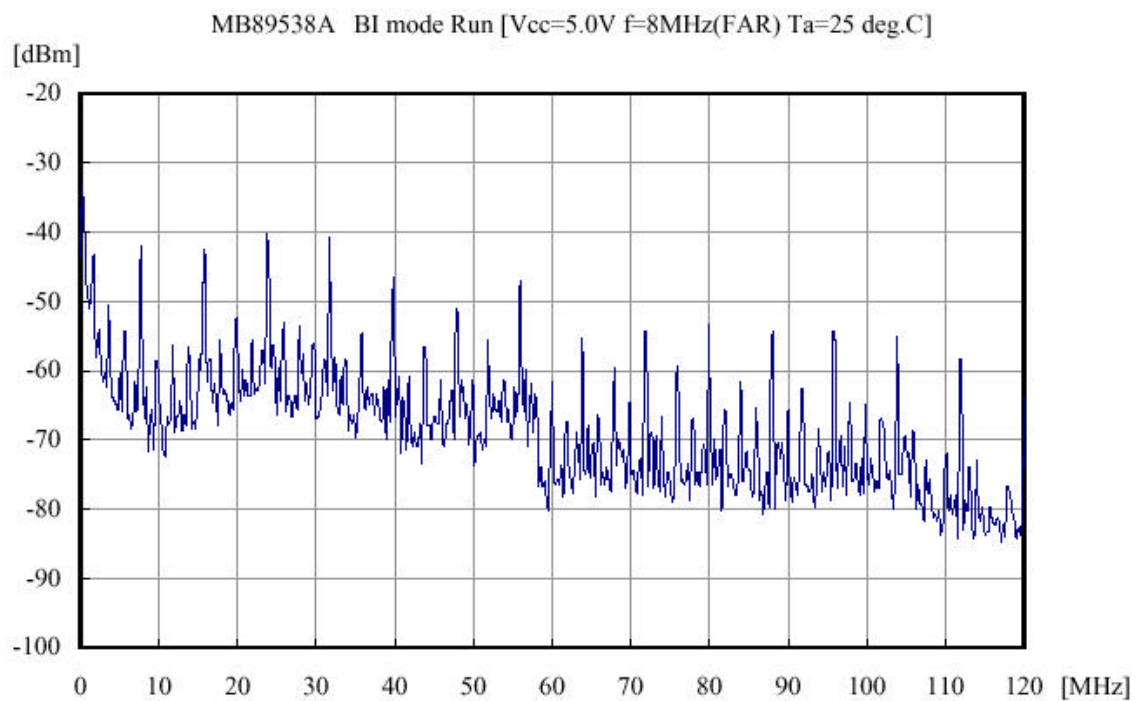

Figure 12: MB89538A - Noise measured on VCC power supply, BI-mode RUN

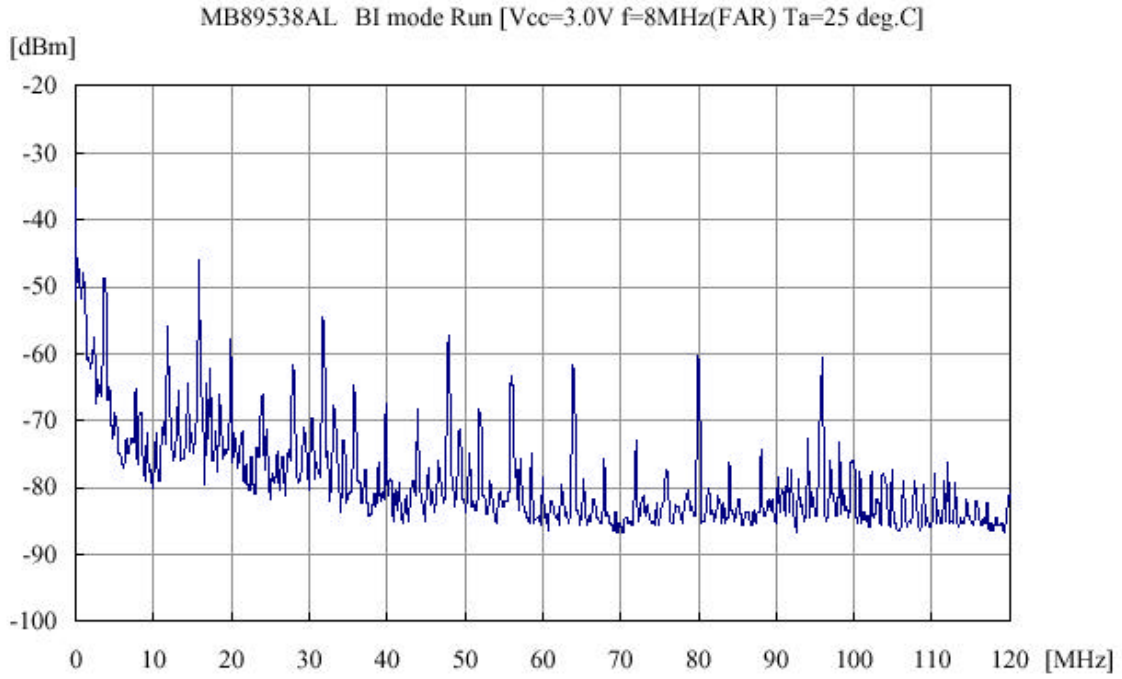

Figure 13: MB89538AL - Noise measured on VCC power supply, BI-mode RUN

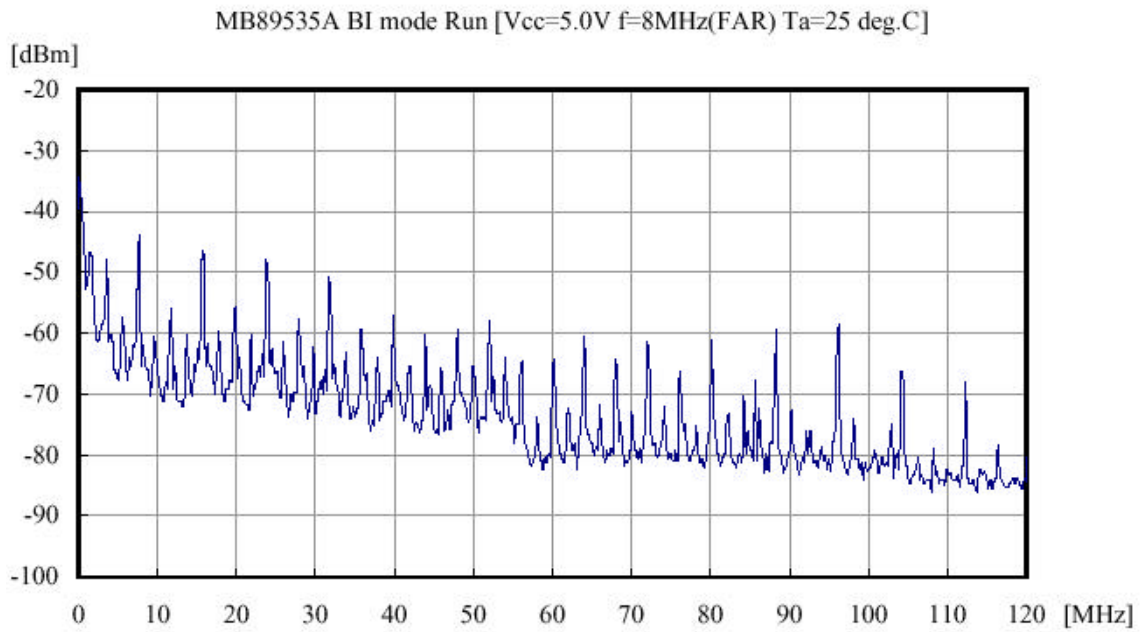

Figure 14: MB89535A - Noise measured on VCC power supply, BI-mode RUN